



Evolution Line MULTIPLICATORI DI GIRI - SPINDLE SPEEDERS

3



MADE IN ITALY

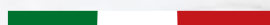

INDICE - INDEX

MOLTIPLICATORI DI GIRI - SPINDLE SPEEDERS

							
GSS-10.HS	GSS-10	GSS-13	GSS-16	GSS-20	GSS-26	GSS-34	performances
3.10	3.11	3.12	3.13	3.14	3.15	3.16	3.17

ACCESSORIES

					
Thru Cool nut	pinze - collets	ghiere / chiavi nuts / wrenches	stop block	esempio di montaggio mounting example	coni / perno shanks / pin
3.19	3.20	3.21	3.22 / 23	3.24 / 25	3.26

Moltiplicatori di giri

Per operazioni di fresatura e foratura

I moltiplicatori di giri sono stati studiati e definiti con l'intento di offrire un prodotto che possa assicurare la massima affidabilità e precisione nelle operazioni di fresatura e foratura.

- Max. 35.000 Rpm
- Lavorazioni ad alta velocità
- Possibilità di montaggio manuale o automatico ed intercambiabili con teste angolari Evolution Line
- Consentono alla macchina di girare a bassi regimi di giri
- Possibilità di utilizzare utensili in metallo duro

La costruzione compatta, i componenti in acciaio trattato termicamente, gli ingranaggi rettificati sull'evolvente permettono la trasmissione di potenze elevate con ottimi livelli di silenziosità. Il mandrino è supportato da cuscinetti a sfere di precisione a contatto obliquo precaricati che gli conferiscono un'elevata rigidità e precisione di rotazione entro mm. 0,01.

- Due ingranaggi satelliti rettificati per elevate potenze trasmissibili
- Attacco utensile speciale a richiesta (Komet, DIN 1835, ecc...)
- Adduzione liquido refrigerante attraverso il centro utensile standard o a richiesta
- Attacco macchina speciale a richiesta (Cono Morse, DIN 69880, ecc...)
- Perno antirotante intercambiabile e perciò personalizzabile dal cliente

da pag 3.1 a 3.26

I moltiplicatori di giri possono essere montati su macchine tradizionali o con cambio utensile automatico.

La lubrificazione è assicurata con grasso a base sintetica a lunga vita che non richiede praticamente interventi di manutenzione.

Il certificato di collaudo che troverete allegato ad ogni moltiplicatore di giri garantisce la qualità del prodotto. Robustezza, versatilità, facilità d'impiego e di manutenzione sono caratteristiche che hanno sempre contraddistinto la nostra produzione ed i moltiplicatori di giri ne sono una conferma.



Spindle Speeders

For milling and drilling operations

The spindle speeders have been designed and developed to offer a product that ensures maximum reliability and accuracy in milling and drilling. From design to static and dynamic testing of the finished product, our spindle speeders use the most advanced technical and technological know-how

- Max 35.000 rpm
- High speed machining
- Manual or automatic tool change option and interchangeable with Evolution line angular heads
- Allow the machine to run at low Rpm
- Possibility of using hard metal tools

The compact construction, the heat-treated steel parts and the ground gears on the involute guarantee transmission of high power ratings with amazingly low noise levels. The spindle is supported by a set of preloaded precision ball bearings with oblique contact that ensure greater strength and rotation precision less than 0,01 mm.

- Two planetary ground gears for high transmission power ratings
- Special tool attachment on request (Komet, DIN 1835, etc.)
- Coolant through the tool centre standard or on request
- Special machine shank connection, on request (Morse Cone, DIN 69880 etc.)
- Interchangeable anti-rotating pin which can therefore be customized by the customer

from pag 3.1 to 3.26

The spindle speeders series can be mounted on traditional machines and on machines with automatic tool change.

The spindle speeders series is lubricated with a long-life synthetic grease that is practically maintenance free.

The test certificate enclosed to each spindle speeders guarantees the quality of the product. Our products have always stood out for their sturdiness, flexibility and easy use and maintenance and the spindle speeders series is an additional proof of such outstanding features



EVOLUTION LINE MOLTIPLICATORI DI GIRI - SPINDLE SPEEDERS



GSS 10

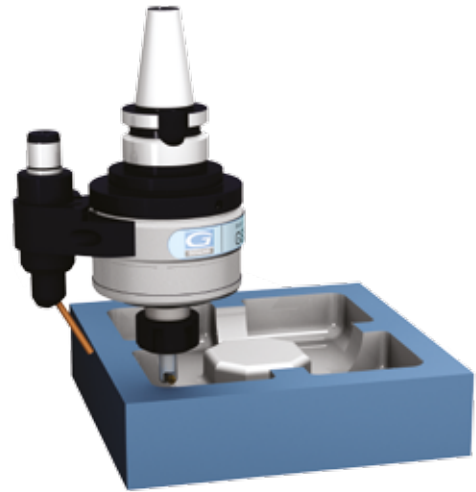

GSS 13





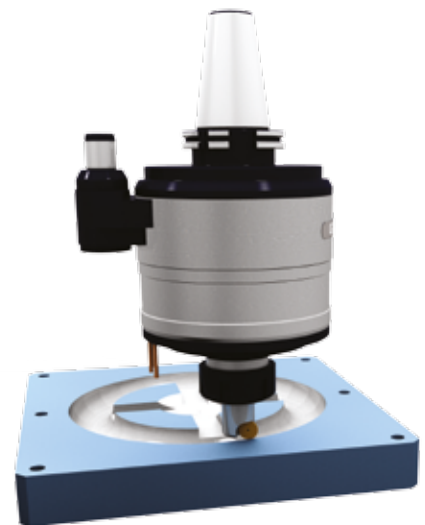

GSS 16





GSS 34

SIMBOLOGIA DATI TECNICI - TECHNICAL DATA LOGOS

							
Rapporto trasmissione Ratio	Numero di giri Revolution per minute Rpm	Potenza massima Max power Kw	Coppia Torque Nm	Peso Weight Kg	Uscita Output Ø	Maschio Tapping M	Pinza Collet Ø

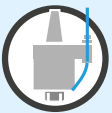
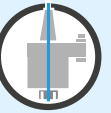
INDICE OPZIONI - OPTIONS INDEX

OPZIONI OPTIONS							Interasse speciale Special pitch		
PASSAGGIO REFRIGERANTE COOLANT							Attaverso il perno Through the Pin 10bar (standard) ROTAZ. a SECCO DRY RUNNING ✓	Cono » Utensile Shank » Tool 70bar ROTAZ. a SECCO DRY RUNNING NO	Perno » Ghiera » Utensile Pin » Distrib » Tool THRU COOL NUT
USCITA OUTPUT							Uscita WELDON WELDON output		

MODULARITÀ SENZA MODULARITY WITHOUT

UNA SOLA TESTA PER PIÙ CENTRI DI LAVORO
ONE HEAD FOR MANY MACHINES

Coni intercambiabili per un utilizzo su più centri di lavoro!! Interchangeable drive tapers to suit any machine spindle!!

3



PERNO DI POSIZIONAMENTO
MODULARE INTERCAMBIABILE A SCELTA
A CHOICE OF MODULAR
INTERCHANGEABLE ARRESTER PINS

**UN INVESTIMENTO CHE
SI RIPAGA VELOCEMENTE !!
QUICKEST RETURN ON YOUR
INVESTMENT !!**

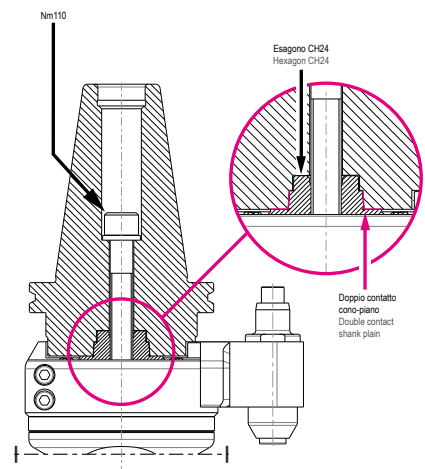

IL DOPPIO CONTATTO CONO E PIANO ASSICURANO
RIGIDITÀ E PRECISIONE !!
THE UNIQUE GERARDI TAPER AND FACE LOCATION
ENSURE RIGIDITY AND ACCURACY !!

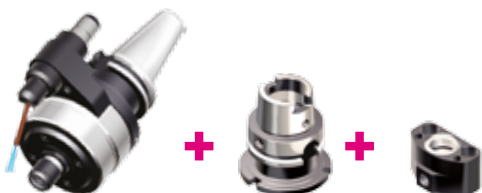

GSS 10 / ISO-40

HSK-63

STOP-BLOCK

COMPROMESSI COMPROMISES

UN SOLO CENTRO DI LAVORO CON PIÙ TESTE
THE SAME MACHINE WITH MANY HEADS

Lavorare nelle migliori condizioni risparmiando sui costi di acquisto !! A system to save costs !!

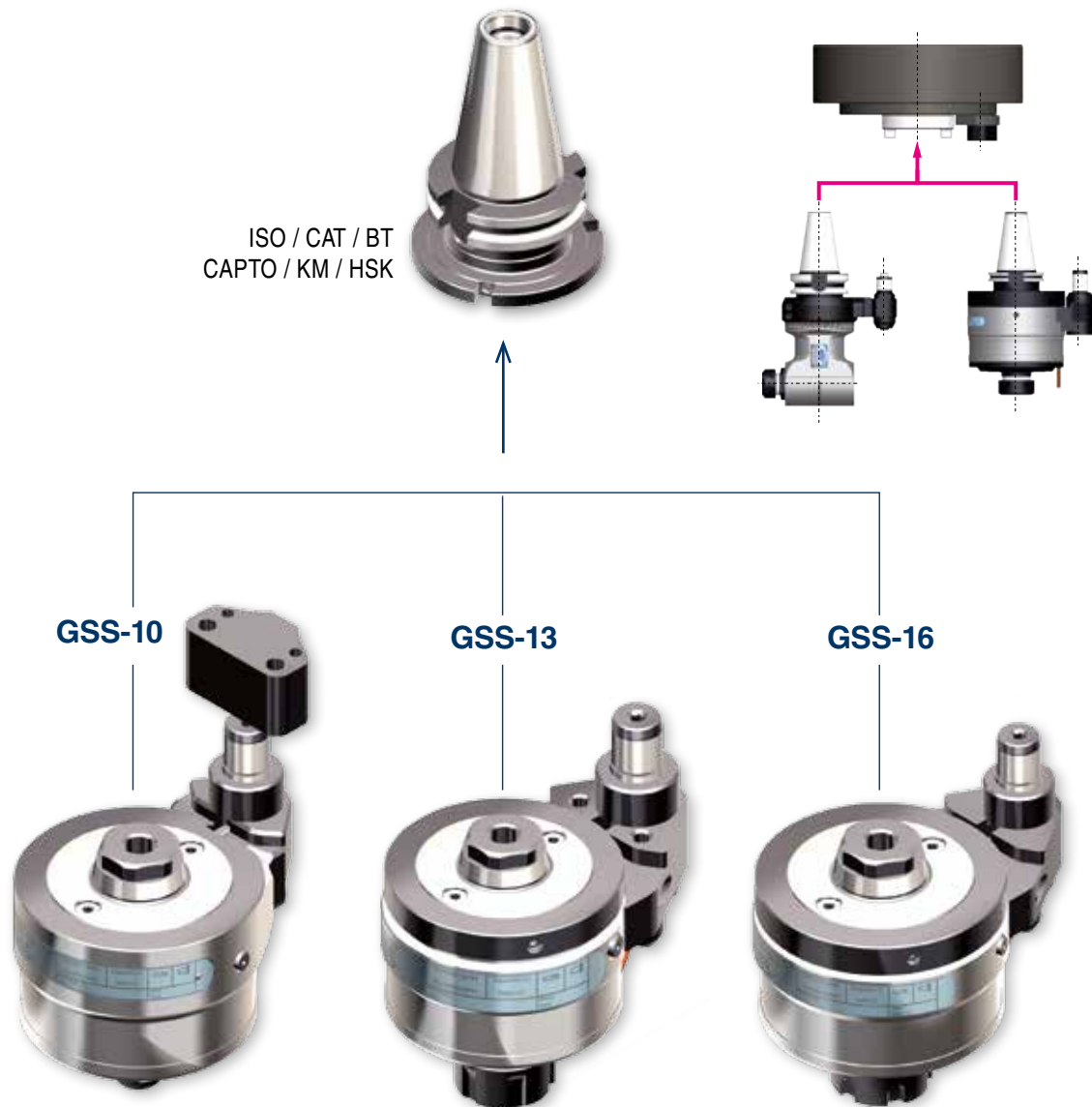

**UNA SOLUZIONE
APERTA PER IL LAVORO DI OGGI,
PENSANDO A QUELLO DI DOMANI !!
BE READY FOR TOMORROW
WITH THE HEAD YOU BUY TODAY !!**

GSS 10.HS

TYPE 1

CODE

9.GS.S10HS

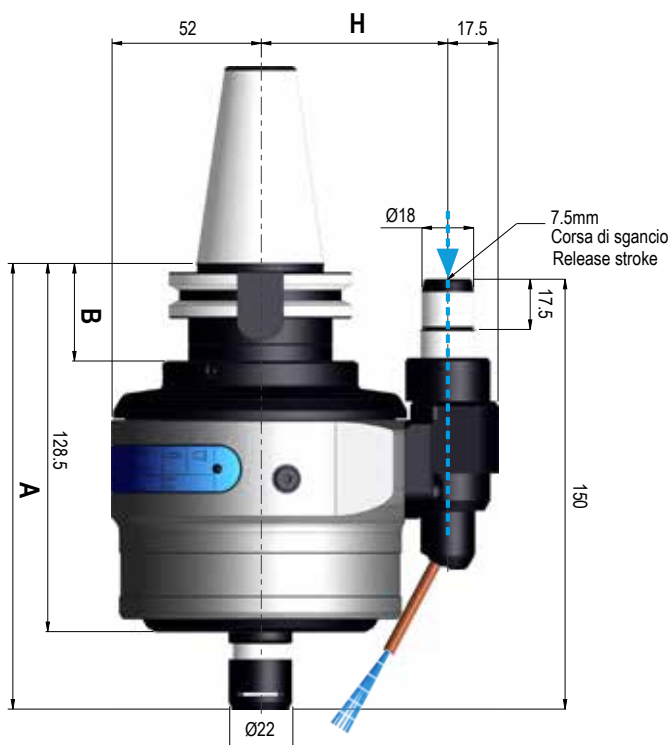

3

REFR. DAL PERNO - COOLANT TROUGH PIN 10 BAR



Ratio
1:8



ISO/BT40
5,8 Kg
ISO/BT50
8 Kg



Rpm Max
35.000



Ø 10



Kw 8,5



ER16
Ø1/10



Nm 3,5

	SK DIN 69871				CAT ANSI B5.50		BT MAS 403			HSK DIN 69893			CAPTO ISO 26623			KM			ISO DIN 2080			NMBT ANSI B5.18	
	30	40	45	50	40	50	30	40	50	63	80	100	C5	C6	C8	63	80	100	40	45	50	40	50
Grandezza - Size	30	40	45	50	40	50	30	40	50	63	80	100	C5	C6	C8	63	80	100	40	45	50	40	50
Prezzi Extra € Extra Price €	optional	std	std	std	optional	optional	optional	std	optional	optional	optional	optional	optional	optional	optional	std	std	std	optional	std	optional	optional	optional
H	Standard	Ø18	65	80	65	80	65	80	65	80	65	80	65	80	65	80	65	80	65	80	65	80	
H	Extra	Ø18	110		-		110		110			110			110			110			110		
H	Extra	Ø28	-	110	-	110	-	110	-	110	-	110	-	110	-	110	-	110	-	110	-	110	
A			155,5		155,5		155,5	163,5	164,5	168,5			163,5			159,5			155,5			155,5	163,5
B			35	42	35	42	35	42	35	44	46	-			-			35	42	35	42	35	42

DOTAZIONE STANDARD STANDARD EQUIPMENT

Peso - Weight: Kg

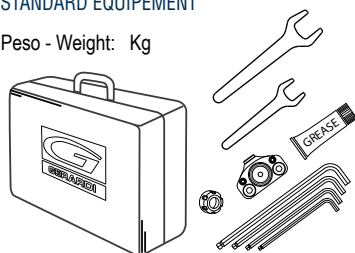

OPZIONI - OPTIONS



DAL CONO
SHANK THROUGH
MAX 70bar

ROTAZ. a SECCO
DRY RUNNING **NO**

optional



PINZA
COLLET

ER16 WP Ø1/10

optional



INTERASSE H
PITCH H

65 ÷ 80

optional

80 ÷ 110

optional

GSS 10

TYPE 1

CODE

9.GS.S1000

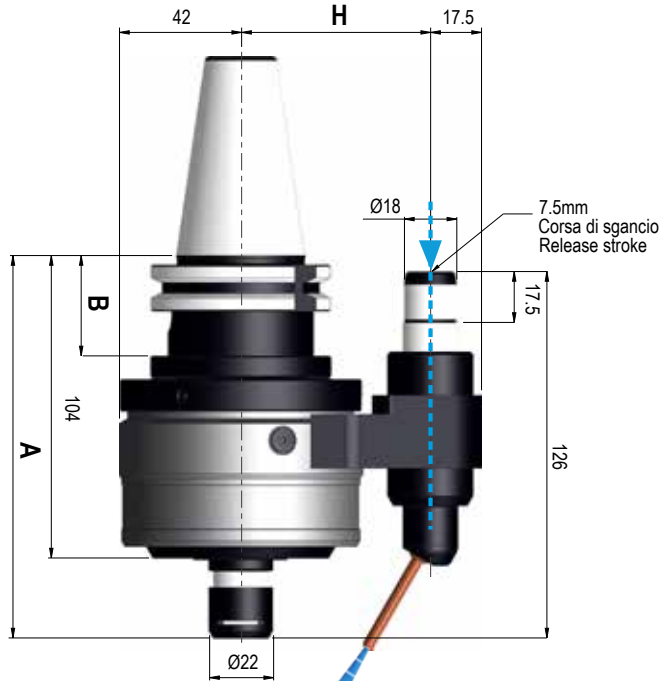

FUORI PRODUZIONE / OUT OF PRODUCTION

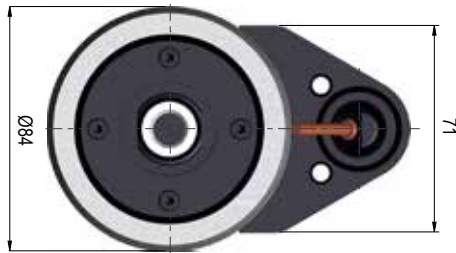

REFR. DAL PERNO - COOLANT TROUGH PIN 10 BAR

- Ratio 1:6
- ISO/BT40 3.7 Kg
- ISO/BT50 6.5 Kg
- Rpm 22.000
- Ø 10
- Kw 5,8
- ER16 Ø1/10
- Nm 2,8

3

	SK DIN 69871		CAT ANSI B5.50		BT MAS 403		HSK DIN 69893			CAPTO ISO 26623			KM			ISO DIN 2080			NMBT ANSI B5.18				
Grandezza - Size	30	40	45	50	40	50	30	40	50	63	80	100	C5	C6	C8	63	80	100	40	45	50	40	50
Prezzi Extra € Extra Price €	optional	std	std	optional	std	optional	optional	std	optional	optional	optional	optional	optional	optional	optional	std	std	std	optional	std	optional	optional	optional
H	Standard	Ø18	65	80	65	80	65	80	65	80	65	80	65	80	65	65	80	65	80	65	80	65	80
*H	Extra	Ø18	110	-	-	110	110	-	110	110	-	110	110	-	110	110	-	110	110	-	110	110	-
H	Extra	Ø28	-	110	-	110	-	110	-	110	-	110	-	110	-	110	-	110	110	-	110	-	110
A			131,5		131,5		131,5	139,5	140,5	144,5			139,5			135,5			101	104,5		101	104,5
B			35	42	35	42	35	50	42	51			-			-			35	42		35	42

DOTAZIONE STANDARD STANDARD EQUIPEMENT

Peso - Weight: MAX Kg.

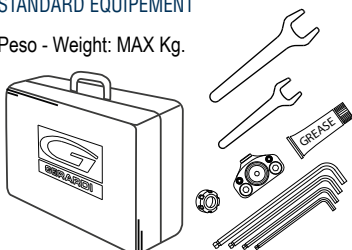

OPZIONI - OPTIONS



PINZA
COLLET

ER16 - Ø1/10

optional



INTERASSE H
PITCH H

65 ÷ 80

optional

80 ÷ 110

optional

GSS 13

TYPE 1

CODE

9.GS.S1300

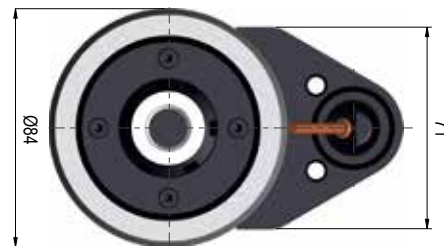
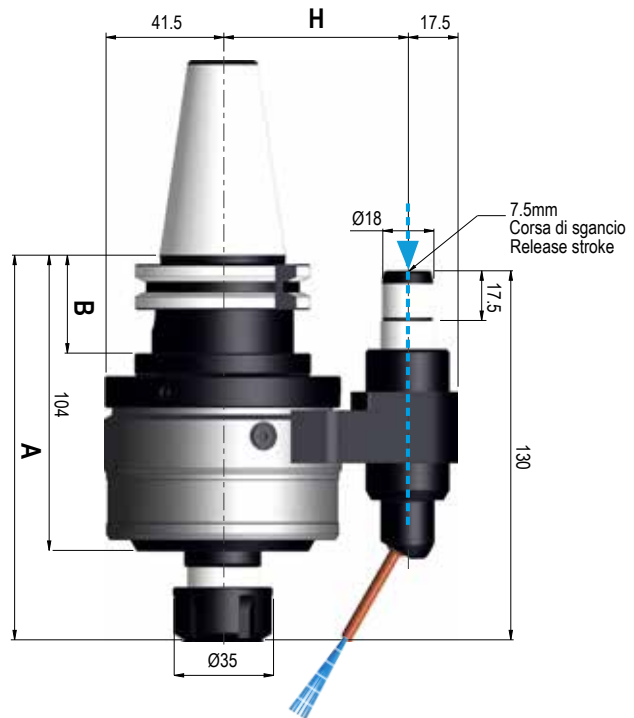

3

REFR. DAL PERNO - COOLANT TROUGH PIN 10 BAR



Ratio
1:6



ISO/BT40
3,7 Kg
ISO/BT50
6,5 Kg



Rpm
22.000



Ø 13



Kw 5,8



ER20
Ø1/13



Nm 2,8

	SK DIN 69871				CAT ANSI B5.50		BT MAS 403			HSK DIN 69893			CAPTO ISO 26623			KM			ISO DIN 2080			NMBT ANSI B5.18	
Grandezza - Size	30	40	45	50	40	50	30	40	50	63	80	100	C5	C6	C8	63	80	100	40	45	50	40	50
Prezzi Extra € Extra Price €	optional	std	optional	optional	optional	optional	optional	std	optional	optional	optional	optional	optional	optional	optional	std	std	std	optional	std	optional	optional	optional
H Standard	Ø18	65	80	65	80	65	80	65	80	65	80	65	80	65	80	65	80	65	80	65	80	65	80
H* Extra	Ø18	110		-		110		110		110		110		110		110		110		110		110	
H Extra	Ø28	-	110	-	110	-	110	-	110	-	110	-	110	-	110	-	110	-	110	-	110	-	110
A		135,5		135,5		135,5	143,5	144,5	148,5	143,5		139,5		135,5	135,5	135,5	135,5	135,5	135,5	135,5	135,5	135,5	135,5
B		35	42	35	42	35	50	42	51	-		-		35	42	35	42	35	42	35	42	35	42

DOTAZIONE STANDARD STANDARD EQUIPMENT

Peso - Weight: Kg

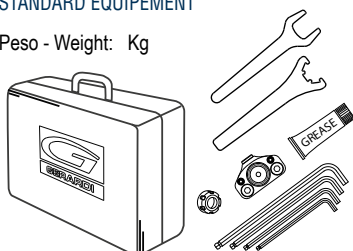

OPZIONI - OPTIONS



PINZA
COLLET

ER20 - Ø1/13

optional



INTERASSE H
PITCH H

65 ÷ 80

optional

80 ÷ 110

optional

GSS 16

CODE

TYPE 2

9.GS.S1600

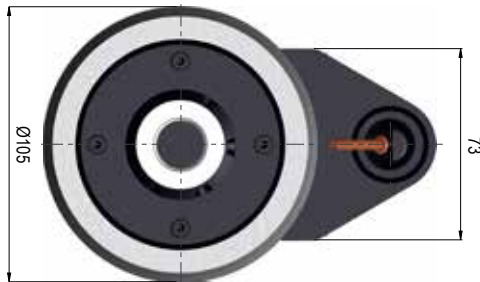
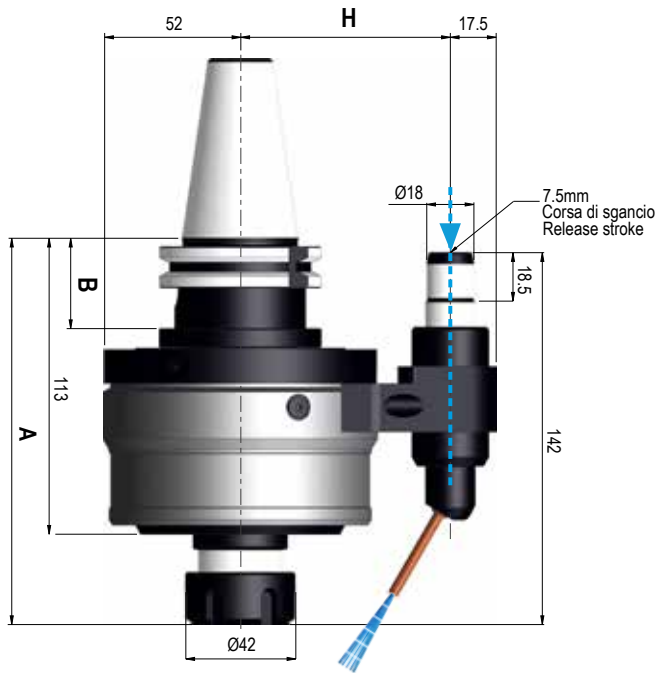

REFR. DAL PERNO - COOLANT TROUGH PIN 10 BAR



Ratio
1:6



ISO/BT40
5 Kg
ISO/BT50
7,5 Kg



Rpm
15.000



Ø 16



Kw 11



ER25
Ø1/16



Nm 7,5

3

	SK DIN 69871			CAT ANSI B5.50		BT MAS 403		HSK DIN 69893			CAPTO ISO 26623			KM			ISO DIN 2080		NMBT ANSI B5.18	
	40	45	50	40	50	40	50	63	80	100	C5	C6	C8	63	80	100	40	50	40	50
Grandezza - Size	40	45	50	40	50	40	50	63	80	100	C5	C6	C8	63	80	100	40	50	40	50
Prezzi Extra € Extra Price €	std	optional	optional	std	optional	std	optional	optional	optional	optional	std	optional	optional	on request			optional	optional	optional	optional
H	Standard	Ø18	80	80	80	80	80	80	80	80	80	80	80	80	80	80	80	80	80	80
*H	Extra	Ø18	110	110	110	110	110	110	110	110	110	110	110	110	110	110	110	110	110	110
H	Extra	Ø28	-	110	-	110	-	110	-	110	-	110	-	110	-	110	-	110	-	110
A			147,5	147,5	147,5	147,5	156,5	160,5			155,5			151,5	147,5	147,5	147,5	147,5	147,5	147,5
B			35	42	35	42	35	50	42	52				-	-	-	35	42	35	42

DOTAZIONE STANDARD STANDARD EQUIPEMENT

Peso - Weight: Kg

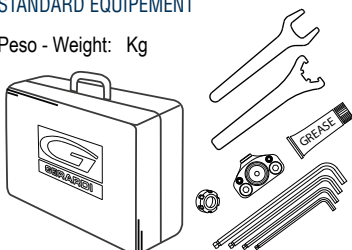

OPZIONI - OPTIONS



PINZA
COLLET
ER25 - Ø2/16
optional



60 mm
80 + 110
optional

GSS 20

CODE

TYPE 2

9.GS.S2000

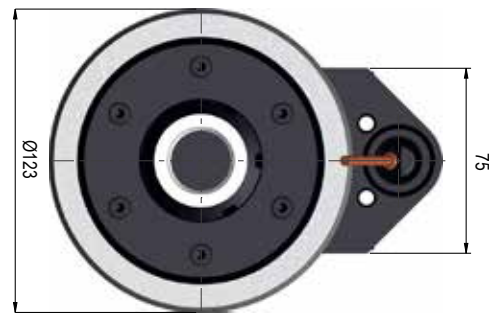
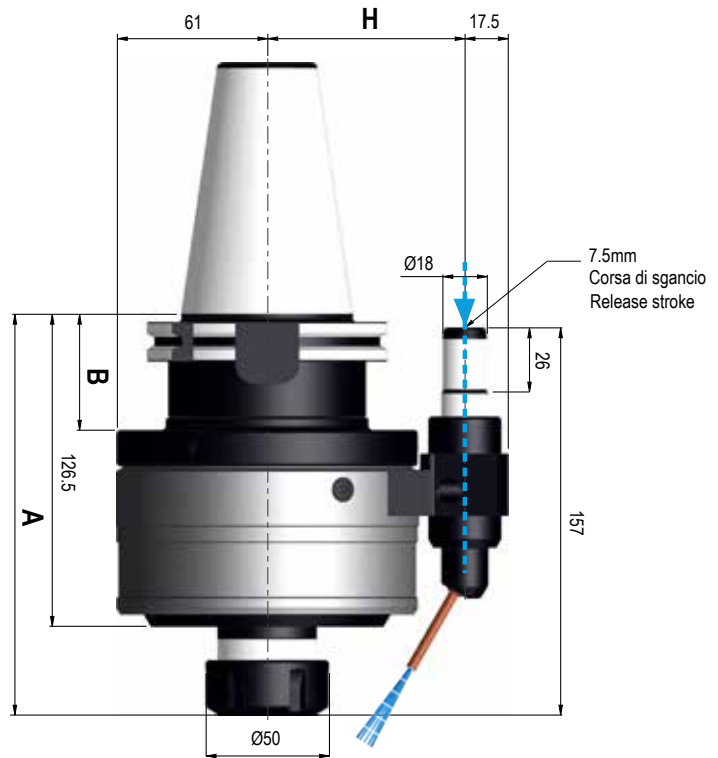

REFR. DAL PERNO - COOLANT TROUGH PIN 10 BAR



Ratio
1:6



ISO/BT40
9 Kg
ISO/BT50
10 Kg



Rpm
12.000



Ø 20



Kw 11



ER32
Ø2/20



Nm 8

	SK DIN 69871	CAT ANSI B5.50	BT MAS 403	HSK DIN 69893	HSK DIN 69893	CAPTO ISO 26623	CAPTO ISO 26623	KM	ISO DIN 2080	NMBT ANSI B5.18		
Grandezza - Size	45	50	50	50	80	100	C6	C8	80	100	50	50
Prezzi Extra € Extra Price €	optional	std	std	std	optional	optional	optional	optional	on request	optional	optional	optional
H Standard Ø18	80	80	80	80	80	80	80	80	80	80	80	80
H Extra	110	110	110	110	110	110	110	110	110	110	110	110
A	162,5	162,5	170,5	171,5	170,5	166,5	162,5	162,5	162,5	162,5	162,5	162,5
B	35	42	35	50	42	55	-	-	42	42	42	42

DOTAZIONE STANDARD STANDARD EQUIPEMENT

Peso - Weight: MAX Kg. 13,2

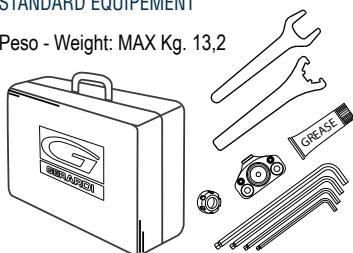

OPZIONI - OPTIONS



PINZA
COLLET
ER32 - Ø2/20
optional



INTERASSE H
PITCH H
80 ÷ 110
optional

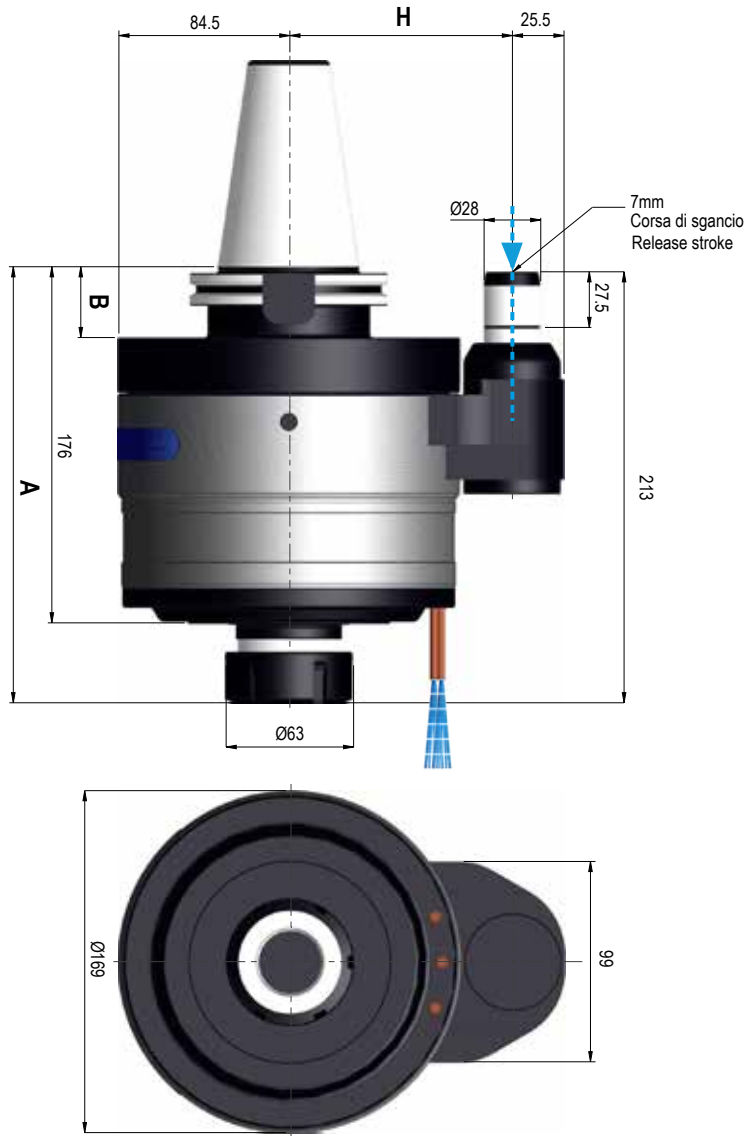

GSS 26

CODE

TYPE 3

9.GS.S2600



REFR. DAL PERNO - COOLANT TROUGH PIN 10 BAR



Ratio
1:4,2



ISO/BT40
- Kg
ISO/BT50
24 Kg



Rpm
10.000



Ø 26



Kw 50



ER40
Ø3/26



Nm 45

3

	SK DIN 69871	CAT ANSI B5.50	BT MAS 403	HSK DIN 69893	CAPTO ISO 26623	KM	ISO DIN 2080	NMBT ANSI B5.18	
Grandezza - Size	50	60	50	50	100	C8	100	50	50
Prezzi Extra € Extra Price €	std	optional	std	optional	on request	on request	on request	optional	on request
H Standard Ø18	110	110	110	110	110	110	110	110	110
H Extra	-	-	-	-	-	-	-	-	-
A	215,5	229	231,5	231,5	234	229	225	215,5	215,5
B	35	48	35	51	53	-	-	35	35

DOTAZIONE STANDARD STANDARD EQUIPMENT

Peso - Weight: Kg

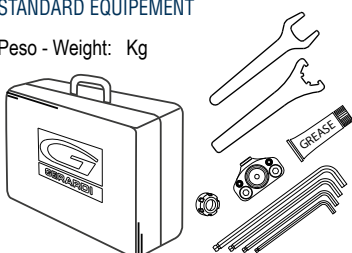

OPZIONI - OPTIONS



DAL CONO
SHANK THROUGH
MAX 70bar

ROTAZ. a SECCO
DRY RUNNING **NO**
optional



PINZA
COLLET

ER40WP Ø3/26
optional



INTERASSE SPECIALE
SPECIAL PITCH

ER40 - Ø3/26
optional

on request

GSS 34

CODE

TYPE 3

9.GS.S3400

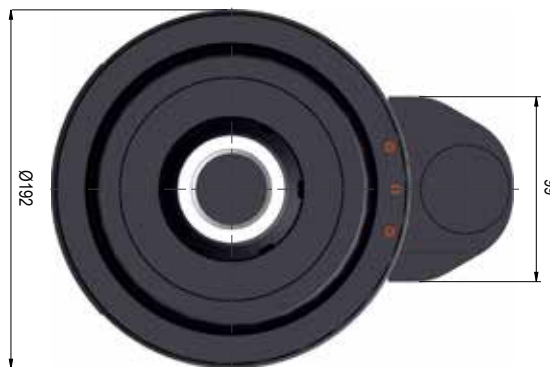
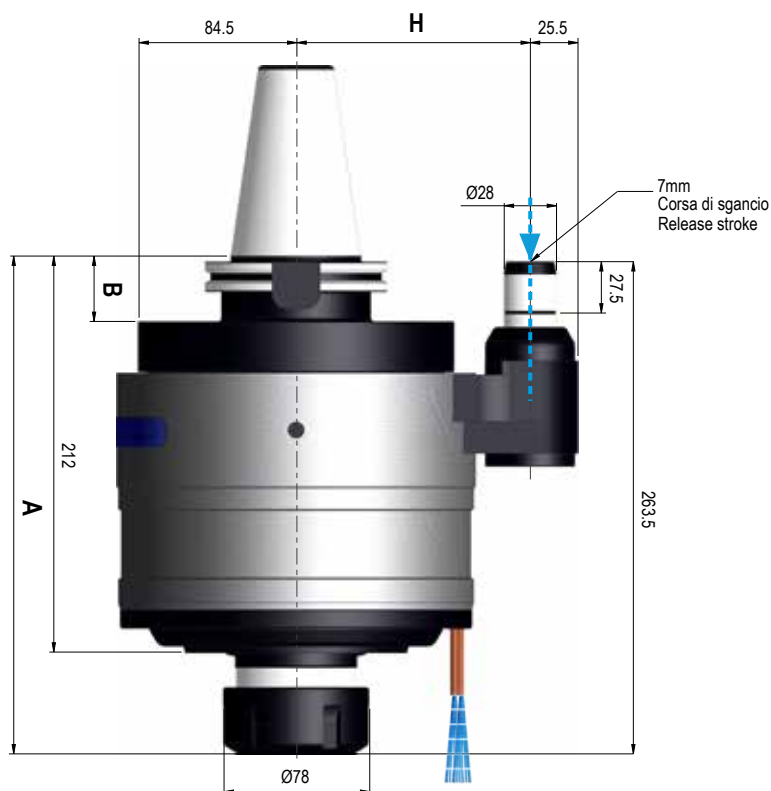

REFR. DAL PERNO - COOLANT TROUGH PIN 10 BAR



Ratio
1:4



ISO/BT40
- Kg
ISO/BT50
36 Kg



Rpm
8.000



Ø 34



Kw 80



ER50
Ø3/34



Nm 90

	SK DIN 69871	CAT ANSI B5.50	BT MAS 403	HSK DIN 69893	CAPTO ISO 26623	KM	ISO DIN 2080	NMBT ANSI B5.50		
Grandezza - Size	50	60	50	50	100	C6 C8	80 100	50 60	50	
Prezzi Extra € Extra Price €	std	optional	on request	optional	on request	on request	on request	optional	optional	on request
H Standard Ø18	125	125	80	125	80	80	80	80		
H Extra	-	-	-	-	-	-	-	-		
A	266	272	282	282	284	279	275	266	266	
B	35	41	36	51	46	-	-	35	35	

DOTAZIONE STANDARD STANDARD EQUIPEMENT

Peso - Weight: Kg

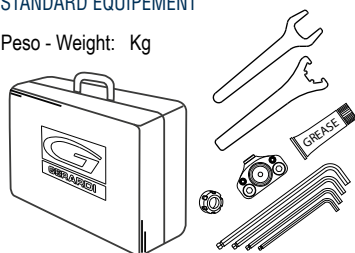

OPZIONI - OPTIONS



DAL CONO
SHANK THROUGH
MAX 70bar

ROTAZ. a SECCO
DRY RUNNING **NO**

optional



USCITA - OUTPUT

Weldon Ø20

optional



PINZA
COLLET

ER50WP Ø3/34

optional

ER50 - Ø3/34

optional

GRAFICI PRESTAZIONI moltiplicatori di giri spindle speeders GRAPHICS PERFORMANCES

GSS - 10.HS

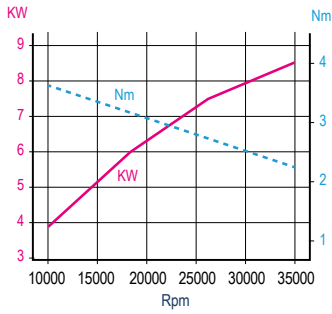

GSS - 10

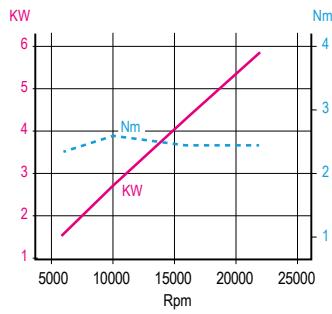

GSS - 13

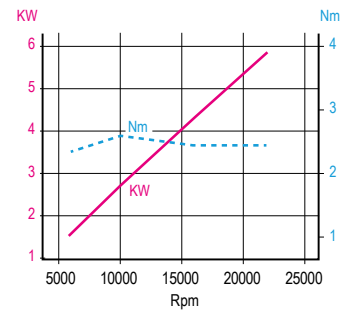

GSS - 16

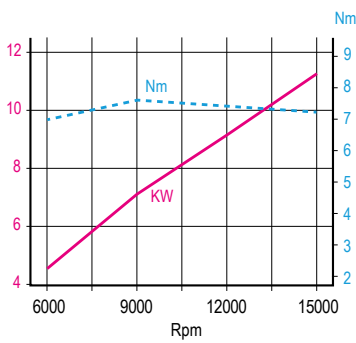

GSS - 20

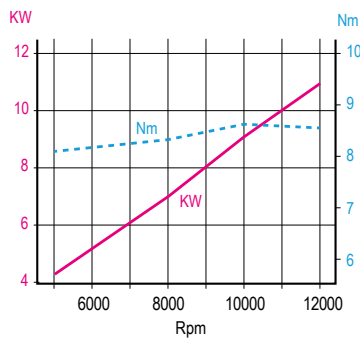

GSS - 26

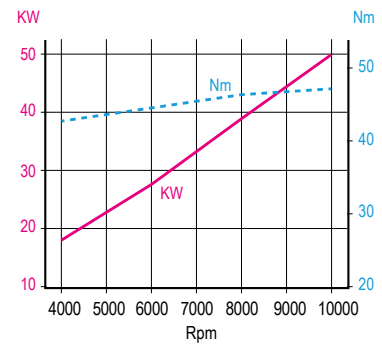

GSS - 34

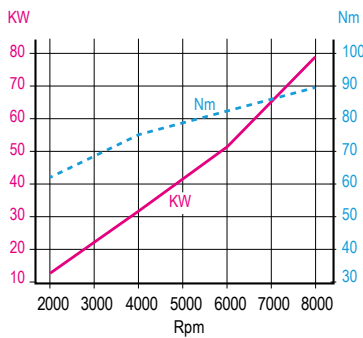

ATTENZIONE

ATTENTION

PER GARANTIRE UN CORRETTO FUNZIONAMENTO DEL MOLTIPLICATORE DI GIRI:

Raccomandiamo ad ogni avvio di farlo girare alcuni minuti ad 1/3 della sua velocità massima di utilizzo, per poi passare alla velocità massima indicata a catalogo che potrà essere mantenuta in modo continuativo.

È importante che venga rispettato il limite coppia massima (Nm), oltre che il numero di giri.

Per un utilizzo in continuo (oltre le 4 ore) la soluzione consigliata è la lubrificazione con MICRO-NEBBIA*.

ATTENZIONE: in caso di materiali molto tenaci, il parametro di riferimento per utilizzo in continuo è la coppia massima disponibile. (Molto limitata nei moltiplicatori di giri).

IN ORDER TO GUARANTEE THE PROPER SPINDLE SPEEDERS WORK:

We recommend to make it run every new start for few minutes at 1/3 (one third) of its Max Rpm then you can go at max speed as indicated on the catalogue which can be kept continuously if used as the torque indicated on the catalogue.

It is important that the Max. torque limit is respected (Nm), as well as Rpm of course.

For continuous use (over 4 hours) the recommended solution is the MICRO-FOG lubricator*.

ATTENTION: in case of very strong materials the limit could be the Max torque available (as spindle speeders have a very limited torque)

* Si consiglia di sottoporre l'applicazione in continuo al nostro ufficio tecnico * Check the use in continuous application with our Technical Department

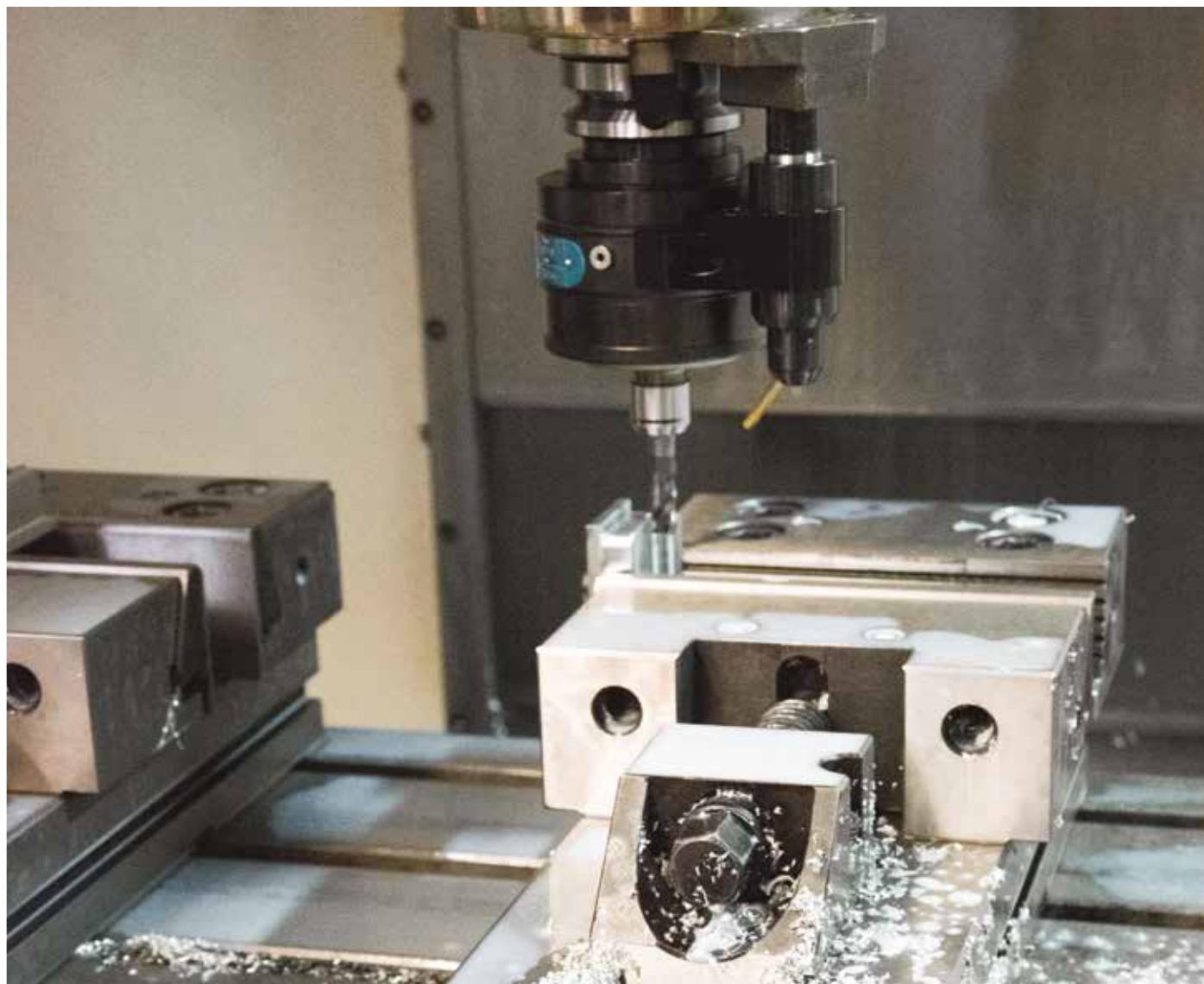

GHIERE ER ReCool ReCool ER NUTS

Con queste ghiera speciali è possibile ottenere il passaggio refrigerante tramite utensile anche su teste che non prevedono questa opzione.

With these special nuts it is possible to get coolant through the tool even on angle heads which do not have this option.

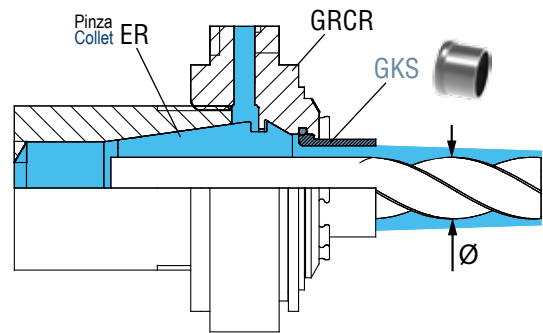
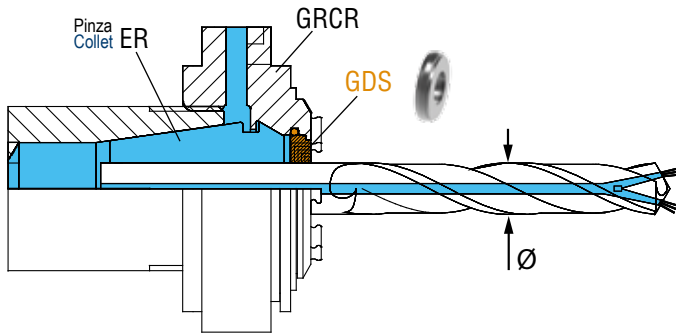

GRCR



GDS



GKS



AX (EXTRA)

MODELLO TESTA ANGOLARE ANGLE HEADS TYPE	Pinza Collet	Ghiera Nut	Disco di tenuta per refr.interno Sealing ring for int. coolant	Disco di tenuta per refr.esterno Sealing ring for est. coolant	Chiavi Wrenches
		Cod.			
GSS 10-HS GSS 10	ER16	GRCR16	GDS16	GKS16	CH-16AX
		9.GR.CR16	9.GD.S16/...	9.GK.S16/...	9.CH.16AX
GSS 13	ER20	GRCR20	GDS20	GKS20	CH-20AX
		9.GR.CR20	9.GD.S20/...	9.GK.S20	9.CH.20AX
GSS 16	ER25	GRCR25	GDS 25	GKS 25	CH-25AX
		9.GR.CR25	9.GD.S25/...	9.GK.S25	9.CH.25AX
GSS 20	ER32	GRCR32	GDS32	GKS32	CH-32AX
		9.GR.CR32	9.GD.S32/...	9.GK.S32	9.CH.32AX
GSS 26	ER40	GRCR40	GDS40		CH-40AX
		9.GR.CR40	9.GD.S40/...		9.CH.40AX

INDICARE SEMPRE IN FASE D'ORDINE Ø UTENSILE - IN CASE OF ORDER SPECIFY THE Ø TOOL

- ER: Pinza ER / ER Collet
- RCR: Ghiera / Nut
- DS: Disco di tenuta / Sealing ring
- KS: Disco di tenuta / Sealing ring

Dotazione Standard Standard Equipment



- 1 - Ghiera con anello esterno
Clamping nut with outer ring.
- 2 - Tubo refrigerante con protezione Ø6mm, 400mm
Coolant pipe with protector Ø6mm, 400mm
- 3 - Raccordi dritti da 1/8" - Fitting 1/8" straight
- 4 - Raccordi a 90° da 1/8" - Fitting 1/8" 90° elbow



Tipo di ghiera Nut type	≤3000 Rpm	≤6000 Rpm	≤9000 Rpm
GRCR/ER 16	5 bar	7,5 bar	10 bar
GRCR/ER 20	5 bar	7,5 bar	10 bar
GRCR/ER 25	5 bar	7,5 bar	10 bar
GRCR/ER 32	5 bar	10 bar	15 bar
GRCR/ER 40	5 bar	10 bar	-

Il tubo e gli accessori in dotazione sono progettati e testati per la pressione massima del refrigerante di 58 bar / 840 PSI. Maggiore pressione del refrigerante su richiesta.

The supplied hose and fittings are designed and tested for maximum coolant pressure of 58 bar / 840 PSI. Higher coolant pressure on request.

Esempio di ordine Ghiera:GRCR16 (Cod. 9.GR.CR16) - Disco tenuta: GDS16-Ø10 (Cod. 9.GD.S16/10)
Example of order Nut: GRCR16 (Cod. 9.GR.CR16) - Sealing ring: GDS16-Ø10 (Cod. 9.GD.S16/10)

PINZE - COLLETS

ER-DIN 6499



Foratura-fresatura / drilling-milling

MODELLO MODEL	PINZA - COLLET	Ø	Cod.	
GSS - 10	ER16 HP	Ø1 / 10	9.ER.11HP0/...	
GSS - 10 HS OPTION 70BAR	ER16 WP	Ø1 / 10	9.ER.16WP0/...	
GSS - 13	ER20 HP	Ø1 / 13	9.ER.20HP0/...	
GSS - 16	ER25 HP	Ø1 / 16	9.ER.25HP0/..	
GSS - 20	ER32 HP	Ø2 / 20	9.ER.32HP0/...	
GSS - 26	ER40 HP	Ø3 / 26	9.ER.40HP0/...	
GSS - 26 OPTION 70BAR	ER40 WP	Ø3 / 26	9.ER.40WP0/...	
GSS - 34	ER50 HP	Ø6 / 34	9.ER.50HP0/...	
GSS - 34 OPTION 70BAR	ER50 WP	Ø6 / 34	9.ER.50WP0/...	

GHIERE BILANCIATE BALANCED NUTS

CHIAVI - WRENCHES

STD

HS

HS

ES

STD

MODELLO MODEL	TIPO GHIERA NUTS TYPE	Cod.		CHIAVI WRENCHES	Cod.	
GSS - 10	ER16 STD	9.ER.16STD		CH-22 ES	9.CH.220ES	
GSS - 10 - HS	ER16 HS	9.ER.160HS		CH-15 HS	9.CH.150HS	
GSS - 13	ER20 STD	9.ER.20STD		CH-27 ES	9.CH.270ES	
				CH-20 STD	9.CH.20STD	
GSS - 16	ER25 STD	9.ER.25STD		CH-36 ES	9.CH.360ES	
				CH-25 STD	9.CH.25STD	
GSS - 20	ER32 STD	9.ER.32STD		CH-32 STD	9.CH.32STD	
				CH-40 HS	9.CH.400ES	
GSS - 26	ER40 STD	9.ER.40STD		CH-40 STD	9.CH.40STD	
				CH-52 ES	9.CH.520ES	
GSS - 34	ER50 STD	9.ER.50STD		CH-50 STD	9.CH.50STD	
				CH-65 ES	9.CH.650ES	

STOP-BLOCK Standard TYPE 1-2

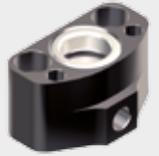

STOP BLOCK Cod.	
9.F18.INDEX	
NO STOP BLOCK INCLUDED	
BUSHING Cod.	
9.F18.INDEX.2	

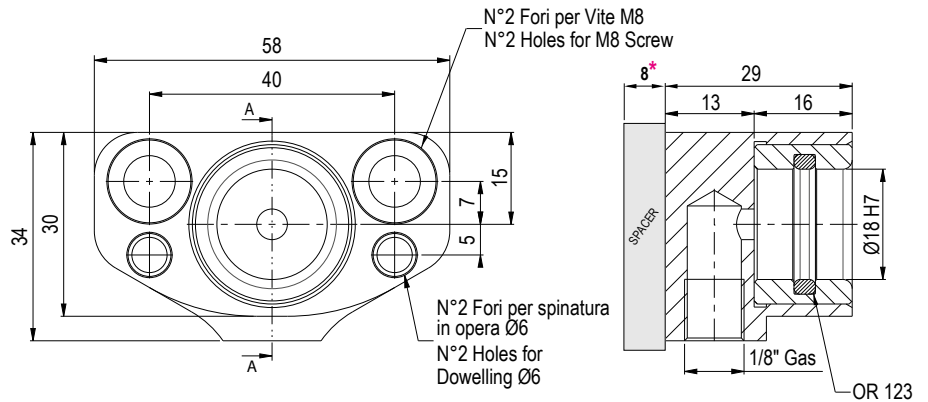

3

STOP-BLOCK Standard TYPE 3



BUSHING Cod.	
9.F28.INDEX	
NO STOP BLOCK INCLUDED	
BUSHING Cod.	
9.F28.INDEX.2	

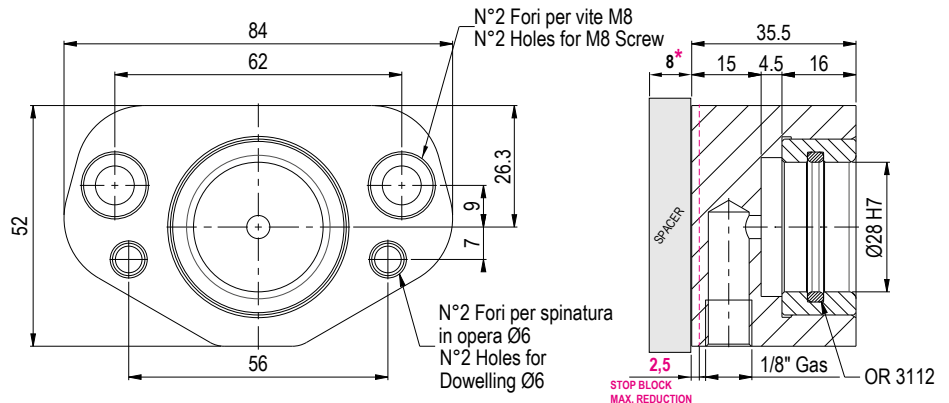

STOP-BLOCK Conico - Conic TYPE 1-2



BUSHING Cod.	
9.F18.INDEXC	
NO STOP BLOCK INCLUDED	
BUSHING Cod.	
9.F28.INDEX.2	

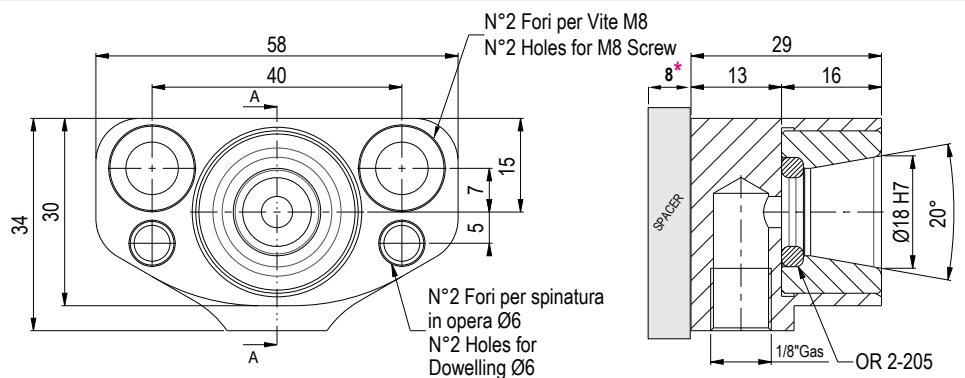

* Misura minima per distanziale sotto la quale è necessario accorciare il perno (Accorciamento massimo del perno 8 / 13mm)
Spacer minimum dimension under this dimension it is necessary to reduce the positioning pin height (Max possible reduction is 8 / 13mm)

STOP-BLOCK Lavorabile - Machineable**

TYPE 1-2

A RICHIESTA - ON REQUEST

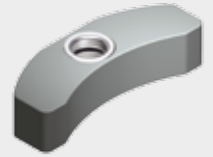

STOP BLOCK	
Cod.	
9.G18.INDEX	
NO STOP BLOCK INCLUDED	
BUSHING	
Cod.	
9.G18.INDEX.2	

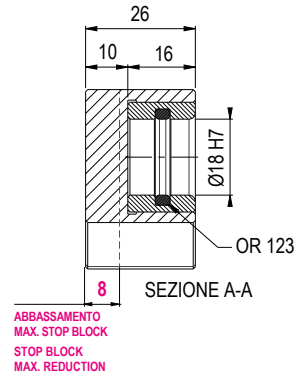
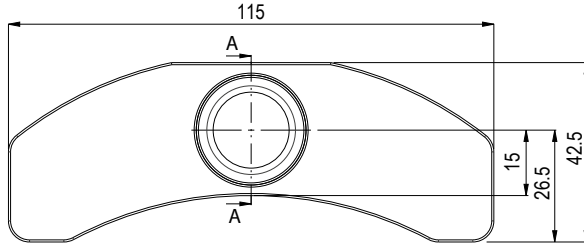

STOP-BLOCK Lavorabile - Machineable**

TYPE 3

A RICHIESTA - ON REQUEST

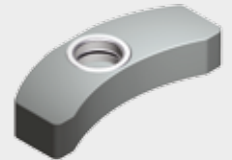

BUSHING	
Cod.	
9.G28.INDEX	
NO STOP BLOCK INCLUDED	
BUSHING	
Cod.	
9.G28.INDEX.2	

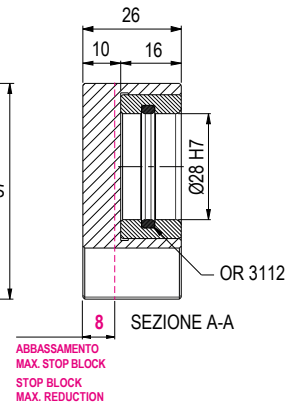
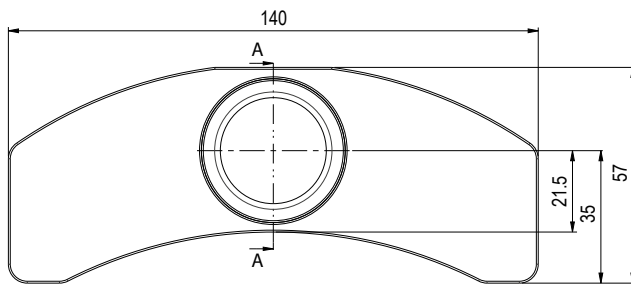

STOP-BLOCK HAAS



STOP BLOCK Cod.	H	CONO	Ø P	
9.INDEX.18_H46	65	40	Ø18	
9.INDEX.18_H48	80	40	Ø18	
9.INDEX.18_H58	80	50	Ø18	
9.INDEX.28_H51	110	50	Ø28	

BUSHING	
Cod.	
9.G18.INDEX.2	
9.G28.INDEX.2	

** Disponibile anche con bussola conica.
** Also available with conic bushing

ESEMPIO di MONTAGGIO serie ATC ATC series MOUNTING EXAMPLE

PER UN CORRETTO ORDINE VERIFICARE L'IDONEITÀ DEL PERNO DI POSIZIONAMENTO
FOR A RIGHT PURCHASE ORDER CHECK THE POSITIONING PIN SUITABILITY

1) STOP-BLOCK GIÀ PRESENTE SUL MANDRINO MACCHINA

- Per i moltiplicatori Gerardi è sufficiente indicare il tipo di moltiplicatore, interasse H, diametro perno ed altezza perno
- In caso di moltiplicatori NON Gerardi, inviateci il disegno dello Stop-block e del mandrino macchina per determinare il perno.
Se possibile si consiglia di smontare lo stop block presente e di utilizzare il nostro standard.

STOP-BLOCK ALREADY MOUNTED ON THE MACHINE SPINDLE

- For Gerardi items, please indicate the type of Spindle Speeder, the H quote, the pin diameter and height.
- For non-Gerardi items, Send Us the stop-block and the machine spindle drawings in order to design the right pin
If possible, we suggest you to use Gerardi standard stop block, taking off the one already placed on the machine.

2) NESSUNO STOP-BLOCK MONTATO SUL MANDRINO MACCHINA

Rilevare la quota X sul mandrino della macchina e mediante la seguente formula calcolare lo spessore del distanziale.
In caso di spessori inferiori a 8 mm è possibile richiedere un apposito stop-block con base lavorabile (Pag. 3.23)

NO STOP-BLOCK MOUNTED ON THE MACHINE SPINDLE

Please check the X quote on the machine spindle and calculate the width of the spacer through the following formula. In case of widths of less than 8 mm, a special stop block with machineable base can be ordered (Pag 3.23)

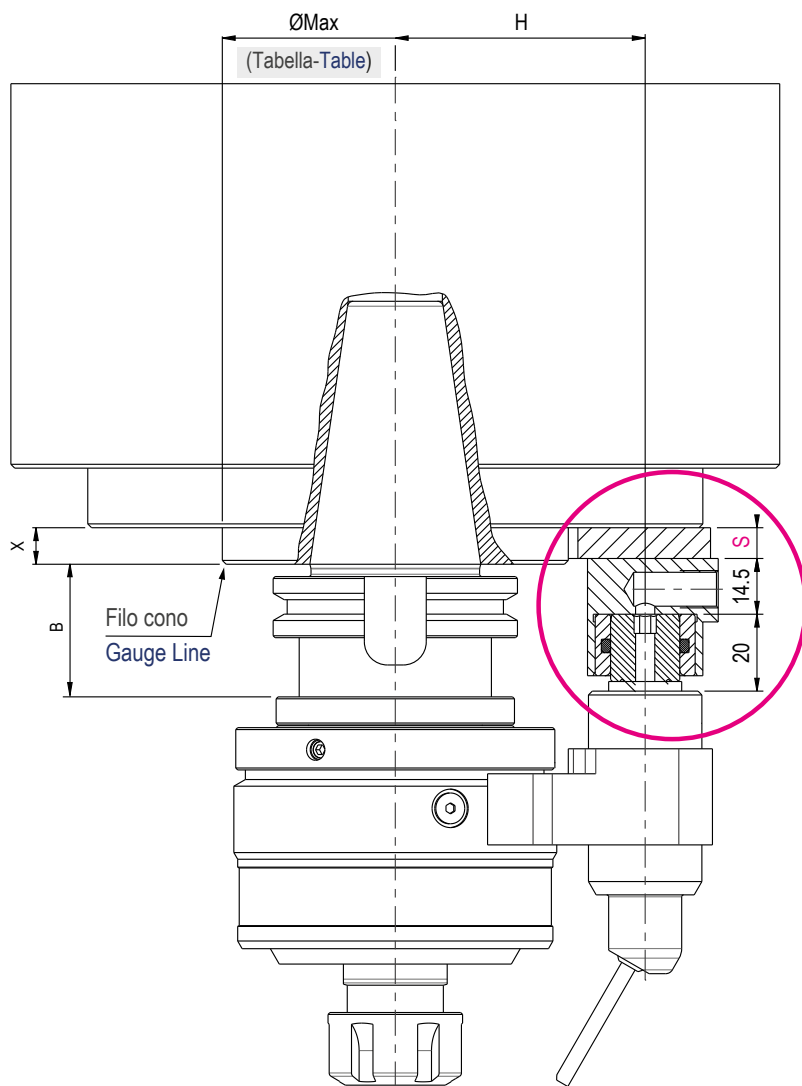

$$S = X + B - 35$$

Se sei in possesso di un moltiplicatore di giri **Tipo 0 / Tipo 1 / Tipo 2**
If you have an Spindle speeders **Type 0 / Type 1 / Type 2**

$$S = X + B - 40,5$$

Se sei in possesso di un moltiplicatore di giri **Tipo 3**
If you have an Spindle speeders **Type 3**

ESEMPIO DI CALCOLO SPESSORE DISTANZIALE
EXAMPLE OF CALCULATION FOR SPACER THICKNESS

X	B
12mm	35mm (SK40)
$S = X (12) + B (35) - 35 = 12$	

ESEMPIO di MONTAGGIO serie ATC

ATC series MOUNTING EXAMPLE

PER UN CORRETTO ORDINE VERIFICARE L'IDONEITA' DELL'INTERASSE "H"
 FOR A RIGHT PURCHASE ORDER CHECK PITCH "H" SUITABILITY

Verificare l'idoneità dell'interasse "H" tramite tabella - Check pitch "H" through table

TABELLA
 TABLE

PERNO - PIN	"H" INTERASSE - PITCH	Ø MAX
Ø18	65	99
	80	129
	110	189
Ø28	110	172

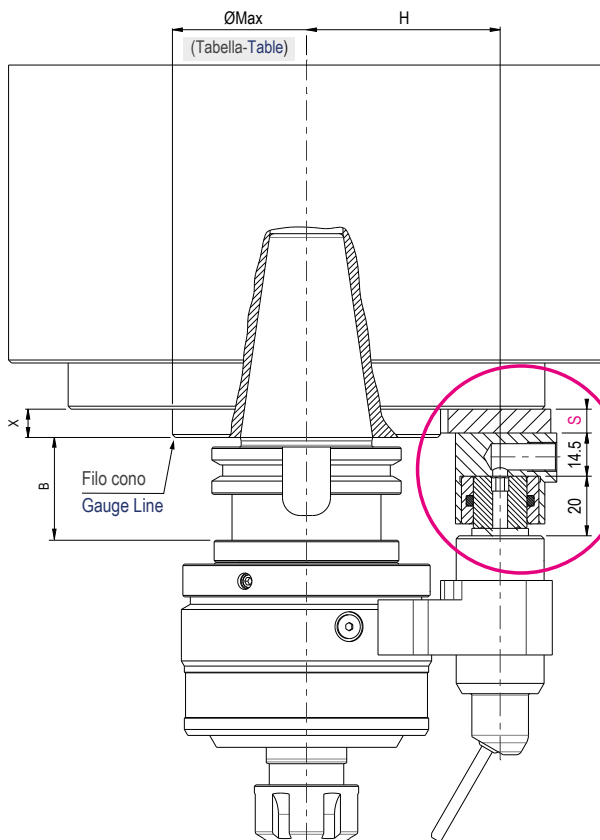

Perno di sgancio
 Release pin

Dettaglio perno
 Pin detail



ATTENZIONE - ATTENTION

Il distanziale per il posizionamento dello stop-block, deve essere realizzato di uno spessore tale da comprimere il perno di sgancio per l'intera corsa.

I calcoli della pagina precedente sono già fatti in tal senso.

The spacer for the stop-block must be done in order to push the release pin for the whole stroke release.

Previous page calculations are already considering this issue.

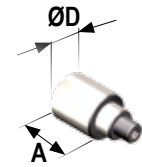
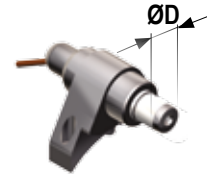
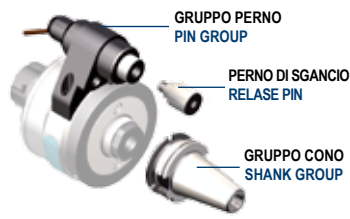

SPINDLE SPEEDERS		KIT INTERFACCIA INTERFACE KIT		GRUPPO CONO SHANK GROUP		GRUPPO PERNO PIN GROUP		PERNO DI SGANCIO RELEASE PIN						
MODELLO MODEL	TIPO TYPE	Cod.		Cod.		DISEGNI DRAWINGS	Cod.	D	Cod.	D	A			
GSS-10.HS	1	9.GA1.SK3065		9.SK30.1GSS		SK DIN 69871 	GSS-10HS	Ø18	9.F18.HS65	9.GS18.P175	Ø18	17,5		
		9.GA1.SK4065		9.SK40.1GSS					9.F18.10.HS80	9.GS18.P175				
		9.GA1.SK5080		9.SK50.1GSS					9.F18.10.HS110	9.GS18.P175				
		9.GA1.CT4065		9.CT40.1GSS		CAT ANSI B5.50 	GSS-10	Ø28	9.F28.10.HS110	9.GS28.P175	Ø28			
		9.GA1.CT5080		9.CT50.1GSS					GSS-13	Ø18			9.F18.101365	9.GS18.P175
		9.GA1.BT4065		9.BT40.1GSS									9.F18.101380	9.GS18.P175
		9.GA1.BT5080		9.BT50.1GSS		BT 	GSS-16	Ø28	9.F18.1013110	9.GS18.P175	Ø28			
		9.GA1.HSK6365		9.HSK63.1GSS					GSS-16	Ø18			9.F28.1013110	9.GS28.P175
		9.GA1.HSK8080		9.HSK80.1GSS									9.F18.1680	9.GS18.P175
		9.GA1.HSK10080		9.HSK100.1GSS		HSK DIN 69893 	GSS-16	Ø28	9.F18.16110	9.GS18.P175	Ø18			
		9.GA1.C56500		9.C5.1GSS					9.F28.16110	9.GS28.P175				
		9.GA1.C68000		9.C6.1GSS										
		9.GA1.C88000		9.C8.1GSS		CAPTO ISO 26623 	GSS-20	Ø18	9.F18.2080	9.GS18.P185	Ø18			
		9.GA1.KM6365		9.KM63.1GSS					GSS-20	Ø28			9.F18.20110	9.GS18.P260
		9.GA1.KM8080		9.KM80.1GSS									9.F28.20110	9.GS28.P260
9.GA1.KM10080		9.KM100.1GSS		KM 	GSS-26	Ø28	9.F28.26110	9.GS28.P275	Ø28					
9.GA1.20804065		9.208040.1GSS					GSS-34	Ø28		9.F28.34125				
9.GA1.20805080		9.208050.1GSS												
GSS-20	2	9.GA2.SK5080		9.SK50.2GSS		ISO DIN 2080 	GSS-26	Ø28			Ø28	27,5		
		9.GA2.CT5080		9.CT50.2GSS										
		9.GA2.BT5080		9.BT50.2GSS										
		9.GA2.HSK8080		9.HSK80.2GSS										
		9.GA2.HSK10080		9.HSK100.2GSS										
		9.GA2.C68000		9.C6.2GSS										
		9.GA2.C88000		9.C8.2GSS										
		9.GA2.KM8080		9.KM80.2GSS										
		9.GA2.KM10080		9.KM100.2GSS										
9.GA2.20805080		9.208050.2GSS												
GSS-26 GSS-34	3	9.GA3.SK50110		9.SK50.3GSS										
		9.GA3.CT50110		9.CT50.3GSS										
		9.GA3.BT50110		9.BT50.3GSS										
		9.GA3.HSK80110		9.HSK80.3GSS										
		9.GA3.HSK100110		9.HSK100.3GSS										
		9.GA3.C6110		9.C6.3GSS										
		9.GA3.C8110		9.C8.3GSS										
		9.GA3.KM80110		9.KM80.3GSS										
		9.GA3.KM100110		9.KM100.3GSS										
9.GA3.208050110		9.208050.3GSS												

ATTENZIONE - ATTENTION: Sui Moltiplicatori è sconsigliabile effettuare il cambio di interasse "H" - On spindle speeders it is not suggested to change pitch dimension "H"