

MTE90 Endmill (High Rake)

MTP90 Endmill

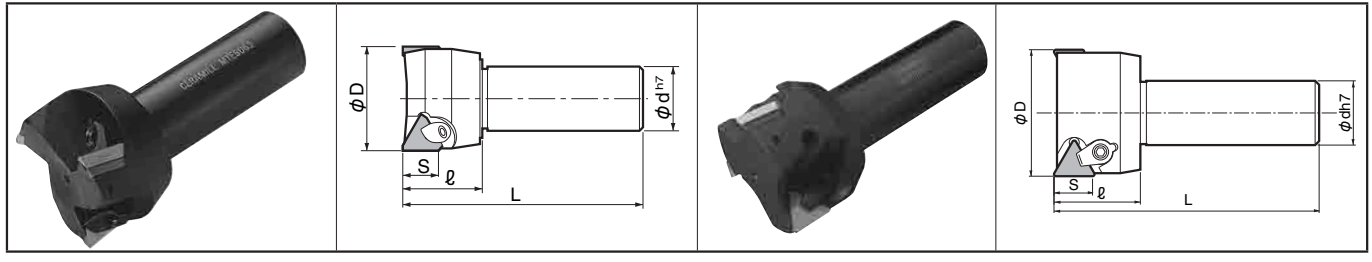

Toolholder Dimensions

Description	Std.	No. of Inserts	Dimension (mm)					Rake Angle (°)		Spare Parts					
			øD	ød	L	ℓ	S	A.R.	R.R.	Clamp	Clamp	Clamp Screw	Wrench	Shim	Clamp Screw
MTE 9050	□	3	50	32	120	40	17	+13°	+3°	-	CP-8TE	W8X18	LW-4	MTE-42	SP3X8
9063	□	3	63												
9080-32	□	4	80												
MTP 9050	□	3	50	32	130	43	18	+8°	0°	CP-8W	-			KPT-42	
9063	□	3	63												

MTE90 Face Mill (High Rake)

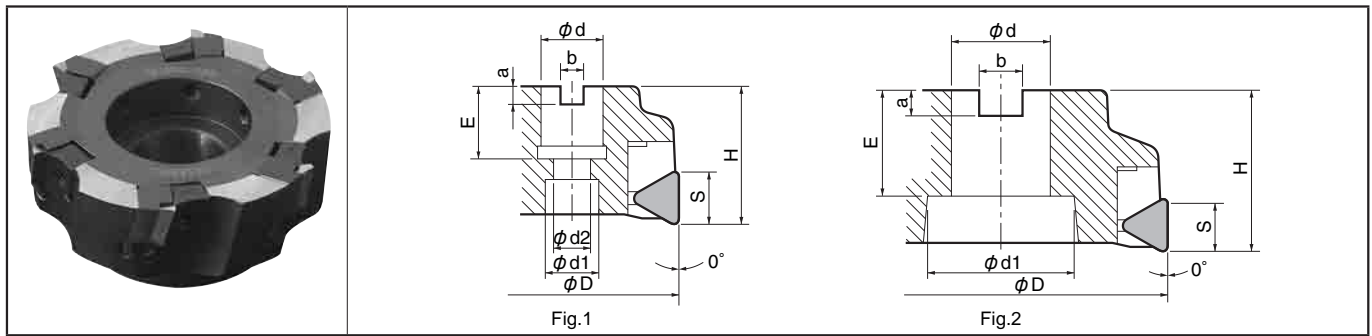

Toolholder Dimensions

* Mounting bolts (HH12X30) are included in MTE90080R and Mounting bolts (HH6X40) are included in MTE900100R

Description	Std.	No. of Inserts	Dimension (mm)										Rake Angle (°)		Drawing	Weight (kg)		
			øD	ød	ød1	ød2	H	E	a	b	S	A.R.	R.R.					
MTE 9080R	□	4	80	25.40	20	14	50	26	6	9.5	17				+16°	+6°	Fig.1	1.3
90100R	□	5	100	31.75	26	18	60	32	8	12.7								2.3
90125R	□	6	125	38.10	58	-	60	38	10	15.9							3.2	
90160R	□	8	160	50.80	68	-	60	38	11	19.0							5.3	

Spare Parts

Description	① Cartridge	② Clamp Screw	③ Clamp	④ Clamp Screw	Wrench
MTE 90...R	LTE-490R	HH4X16	C17R	W8X18	TH-4

Applicable Inserts

Toolholder	Applicable Inserts M12				Applicable Inserts M20	
	TEMR 2204PTER-H	TEKR 2204PTER-S	TEEN 2204PTTR	TEKN 2204PTTR	TEKN 2204PTFR	TEKN 2204PTFR-NE (PCD)
MTE 90...						
MTP 90...	TPMR 2204PDER-H	TPKR 2204PDER-S	TPKN 2204PDTR	TPKN 2204PDRF		-

● : Std. Item □ : Check Availability

For recommended cutting conditions, see page M44

