

MSD45 Endmill

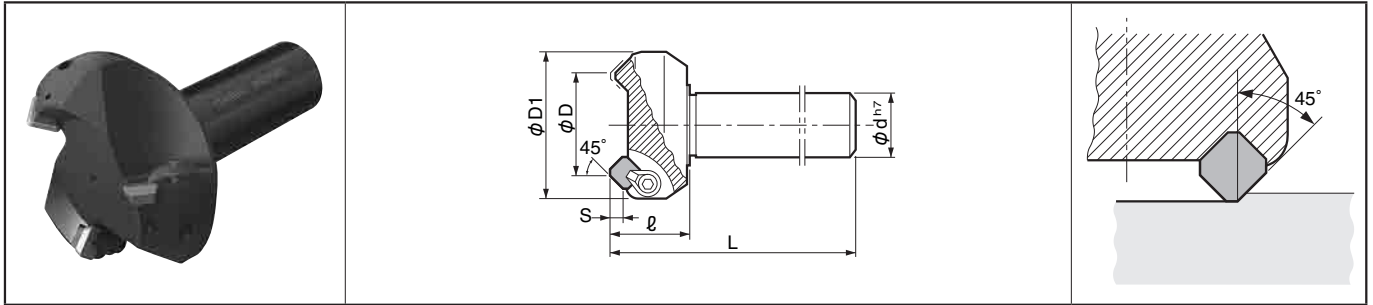

Toolholder Dimensions

Description	Std.	No. of Inserts	Dimension (mm)						Rake Angle (°)		Spare Parts									
			øD	øD1	ød	L	ℓ	S	A.R.	R.R.	Clamp Set	Wrench	Shim	Clamp Screw						
MSD 4550	<input type="checkbox"/>	3	50	73																
4563	<input type="checkbox"/>	3	63	87	32	120	40	6.5	+16°	-3°	CPS-6M	LW-3	MSD-42	SP3X8						
4580-32	<input type="checkbox"/>	4	80	104																

MSD45 Face Mill

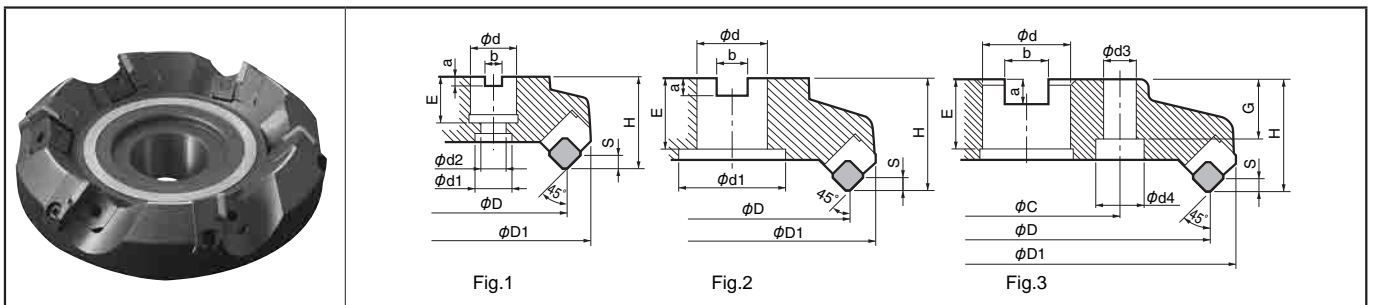

Toolholder Dimensions

Description	Std.	No. of Inserts	Dimension (mm)													Rake Angle (°)		Drawing	Weight (kg)							
			øD	øD1	ød	ød1	ød2	ød3	ød4	øC	H	E	G	a	b	S	A.R.			R.R.						
MSD 4580R	<input type="checkbox"/>	4	80	106	25.40	20	14							50	26		6	9.5						Fig.1	1.9	
45100R	<input type="checkbox"/>	5	100	126	31.75	48									32		8	12.7								2.9
45125R	<input type="checkbox"/>	6	125	151	38.10	58								60			10	15.9	6.5	+15°	-3°		Fig.2	4.1		
45160R	<input type="checkbox"/>	8	160	186	50.80	68									38		11	19.0							6.1	
45200R	<input type="checkbox"/>	10	200	226	47.625	-			18	26	101.6					38	14	25.4					Fig.3	9.3		

Spare Parts

Description	① Cartridge	② Clamp Screw	③ Clamp	④ Clamp Screw	Wrench
MSD 45...R	LSD-445R	HH4X16	C20R	TH8X15	TH-4

* Mounting bolt(HH12X30) is included for MSD4580R

Applicable Inserts

Toolholder	Applicable Inserts M10			Applicable Inserts M20	
	MSD 45...	SDMR 1203AUER-H	SDKR 1203AUEN-S	SDCN 1203AUTN SDKN 1203AUTN 1203AUFN	SDKN 1203AUFN-NE 1203AUFN (PCD)

For recommended cutting conditions, see page **M155**

● : Std. Item □ : Check Availability