

**Tool Looking Stand**

**Features:**

- Set tools either horizontally or vertically simultaneously.
- Setting NC tooling easily and efficiently.
- Low cost and great value.



Ordering Code	Type	Taper
381020-130	TLS-30	BT30
-140	-40	BT40
-150	-50	BT50
382020-140	TLS-40-SK	SK40
-150	-50-SK	SK50

**Tool Locking Fixture**

**Features:**

- Easy handing and low cost tool locking fixture on work bench for preparing tools for machining centers.
- Swivel in vertical and horizontal.
- It is recommended to fix the base plate on the working bend.

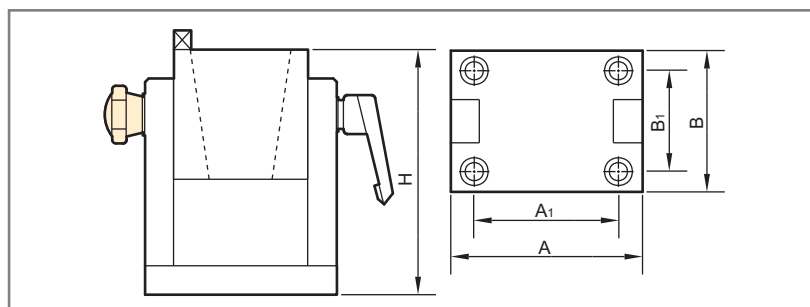

Ordering Code	Type	Taper	H	A	A1	B	B1
381010-30	TBS-30	BT30	120	180	80	80	60
-40	-40	BT40	130				
-50	-50	BT50	170	133	100	98	70

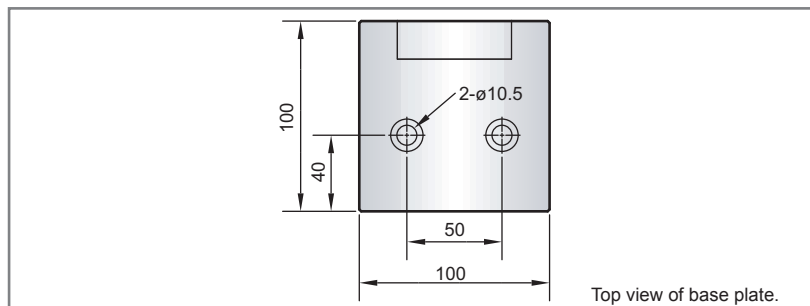

Ordering Code	Type	Taper
381650-040	HL-HSK40	HSK40A / HSK40E
-050	HL-HSK50	HSK50A / HSK50E NSK30
-603	HL-HSK63	HSK63A / HSK63E HSK63F