

MILLLINE Shoulder milling cutter

TUNGQUAD

TPD / EPD / ELD type

**Extended version
with roughing type**

Small diameter cutters that deliver highly productive solutions



Ideal solution for milling small parts on small machine !



Features

● Super high density cutters

Small diameter cutter delivers very high productivity levels !

■ Comparison of number of teeth

Tool diameter ϕD_c (mm)	$\phi 25$	$\phi 32$	$\phi 40$
TUNGQUAD	5	6	8
Conventional	4	5	6
Competitor	3	4	5



- Air hole**
Improves chip evacuation
- Ni-plated cutter bodies**
Tough surface prevents scratching

● High performance with economical inserts

Four edged positive insert !

Chipbreakers	Work material	Shape	Features	Cross-sections of the cutting edge (Outline figure)
MJ	P Steel M Stainless K Cast Iron		Well balanced sharpness and strength	
AJ	N Non-ferrous		Sharp edge and lapped surface	

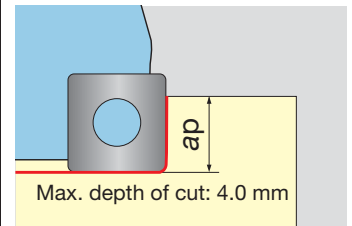

Cutting performance

Application Range for Steel, S55C (C55E)

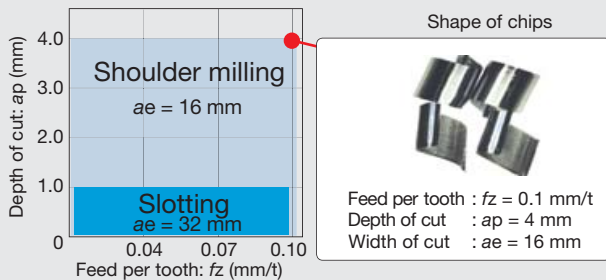

Cutter : TPD05R032M16.0E06 ($\phi 32$ mm)
Insert : SDMT050204PN-MJ
Grade : AH725
Cutting speed : $V_c = 180$ m/min
Cutting fluid : Dry cutting
Machine : Vertical M/C, BT30

Application Range for Aluminium, A7020 (EN AW-7020)

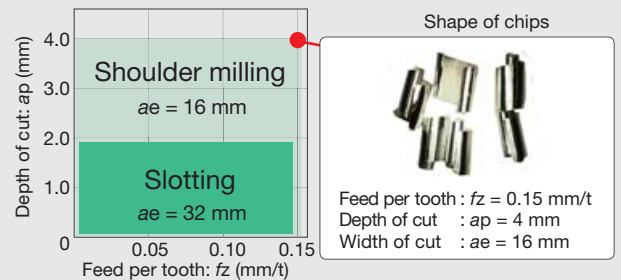

Cutter : TPD05R032M16.0E06 ($\phi 32$ mm)
Insert : SDHT050204FN-AJ
Grade : TH10
Cutting speed : $V_c = 400$ m/min
Cutting fluid : Dry cutting
Machine : Vertical M/C, BT30

Practical examples

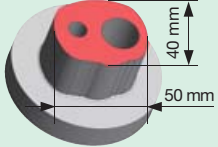
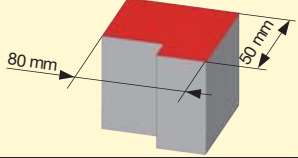
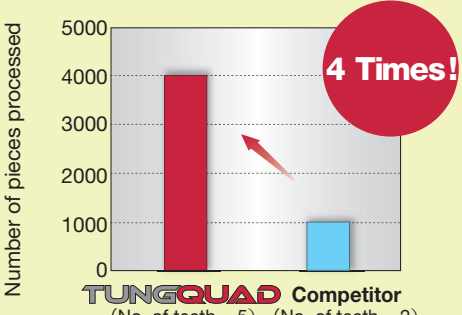
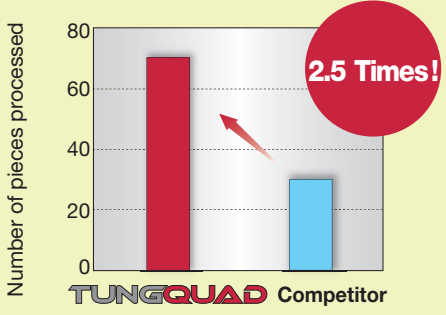
Work piece type		Compressor parts	Machine parts
Toolholder		EPD05R025M20.0W05	EPD05R040M32.0W08
Insert		SDHT050204FN-AJ	SDMT050204PN-MJ
Grade		TH10	AH140
Work material		Aluminium alloys ADC12	Stainless steels SUS304 (X5CrNi18-10)
			
Cutting conditions	Cutting speed : V_c (m/min)	314	150
	Feed per tooth: f_z (mm/t)	0.08	0.06
	Depth of cut : a_p (mm)	1	3.5
	Width of cut : a_e (mm)	25	2
	Coolant	Water soluble	Dry
Results		 <p>4 Times!</p> <p>Productivity is Doubled ! (Feed speed $V_f = 700$ mm/min \rightarrow 1500 mm/min)</p>	 <p>2.5 Times!</p> <p>No chipping on the edge. Stable machining.</p>



Inserts

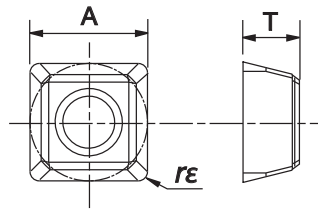

■ Insert

Cat. No.	Accuracy	Honing	Stock			Dimensions (mm)			Cutter
			Coated grades		Carbide	A	T	rE	
			AH725	AH140	TH10				
SDMT050204PN-MJ	M	with	●	●		5.09	2.38	0.4	TPD05..., EPD05... ELD05...
SDHT050204FN-AJ	H	without			●	5.09	2.39	0.4	

Standard cutting conditions

■ Bore, shank type

Work material	Brinell hardness HB	Grades	Cutting Speed Vc (m/min)	Feed per tooth fz (mm/t)
Low carbon steels S15C / C15E4 etc.	~ 200	AH725	230 - 320	0.04 - 0.10
High carbon steels S45C / C45 etc.	200 ~ 300		150 - 230	
Alloyed steels SCM440 / 42CrMo4 etc.	150 ~ 300		110 - 130	
Tool steels SKD11 / X153CrMoV12 etc.	~ 300			
Stainless steels SUS304 / X5CrNi18-9 etc.	-	AH140	100 - 200	0.03 - 0.09
Grey cast irons FC250 / 250 etc.	150 ~ 250	AH725	200 - 300	0.05 - 0.12
Ductile cast irons FCD400 / 450-10S etc.			160 - 240	0.05 - 0.12
Aluminium alloys (Si < 13%)	-	TH10	350 - 500	0.05 - 0.15
Aluminium alloys (Si ≥ 13%)	-		100 - 200	

* For deep and wide cutting, set the Vc and fz to the lower recommended limits and check the vibration and spindle load of the machine.

■ Roughing type

Work material	Brinell hardness HB	Grades	Cutting Speed Vc (m/min)	Feed per tooth fz (mm/t)
Low carbon steels S15C / C15E4 etc.	~ 200	AH725	100 - 250	0.04 - 0.10
High carbon steels S45C / C45 etc.	200 ~ 300		100 - 200	
Alloyed steels SCM440 / 42CrMo4 etc.	150 ~ 300		100 - 130	
Tool steels SKD11 / X153CrMoV12 etc.	~ 300			
Stainless steels SUS304 / X5CrNi18-9 etc.	-	AH140	100 - 150	0.03 - 0.09
Grey cast irons FC250 / 250 etc.	150 ~ 250	AH725	100 - 250	0.05 - 0.12
Ductile cast irons FCD400 / 450-10S etc.			80 - 200	0.05 - 0.12
Aluminium alloys (Si < 13%)	-	TH10	200 - 500	0.05 - 0.15
Aluminium alloys (Si ≥ 13%)	-		100 - 200	

Cutters

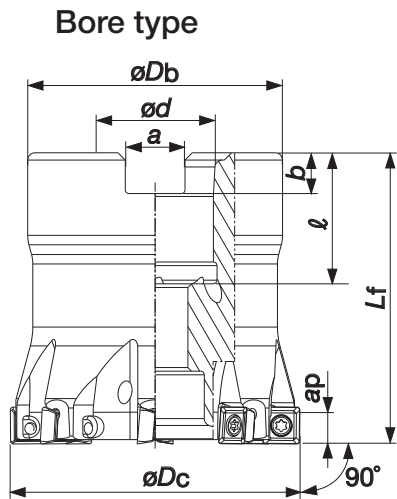

Shank type

straight

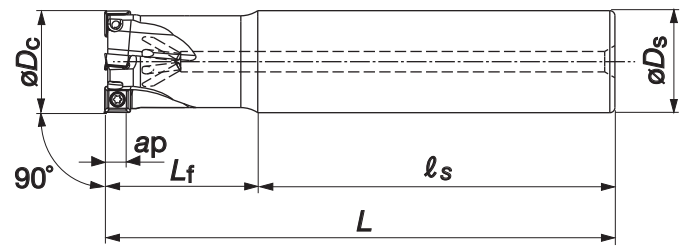

weldon

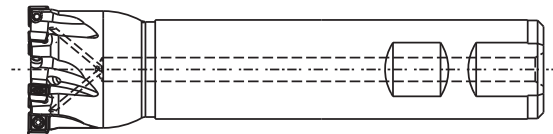

Descriptions	Parts Cat. No.
Clamping screw	CSPB-2L043
Wrench	IP-6DB

■ Bore type

Cat. No.	Stock	No. of Inserts	Dimensions (mm)							Weight (kg)	Air hole	Cutter mounting screw	Inserts
			ϕDc	ϕDb	ϕd	ℓ	L_f	b	a				
TPD05R032M16.0E06	●	6	32	30	16	20	32	5.6	8.4	0.1	with	CM8x30H	SDMT050204PN-MJ
TPD05R040M22.0E08	●	8	40	38	22	22	40	6.3	10.4	0.2	with	CM10x30H	SDHT050204FN-AJ

Max. $ap = 4$ mm

■ Shank type

Cat. No.	Stock	No. of Inserts	Dimensions (mm)					Weight (kg)	Air hole	Shank type	Inserts
			ϕDc	ϕDs	ℓ_s	L_f	L				
EPD05R012M12.0-02	●	2	12	12	62	18	80	0.1	with	straight	SDMT050204PN-MJ SDHT050204FN-AJ
EPD05R016M16.0-03	●	3	16	16	90	20	110	0.2	with	straight	
EPD05R020M20.0W04	●	4	20	20	80	25	105	0.2	with	weldon	
EPD05R025M20.0W05	●	5	25	20	90	25	115	0.3	with	weldon	
EPD05R032M25.0W06	●	6	32	25	98	32	130	0.5	with	weldon	
EPD05R040M32.0W08	●	8	40	32	100	40	140	0.8	with	weldon	

Max. $ap = 4$ mm

NEW Roughing type

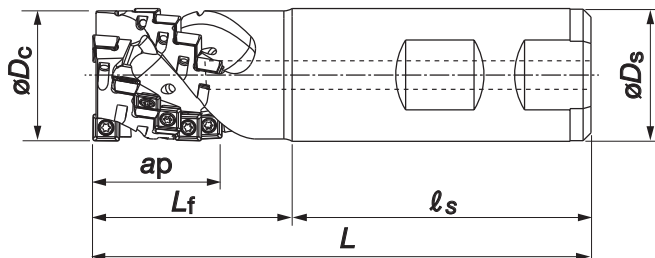

■ Roughing type

Cat. No.	Stock	No. of eff. edge lines	Dimensions (mm)						Weight (kg)	Air hole	Inserts
			ϕDc	ϕDs	ℓ_s	L_f	L	ap			
NEW ELD05R020M20.0W02	●	2/10	20	20	53	32	85	20.3	0.2	with	SDMT050204PN-MJ
NEW ELD05R025M25.0W03	●	3/18	25	25	59	36	95	24.2	0.3	with	SDHT050204FN-AJ

● : Stocked items



Tungaloy Corporation (Head office)

11-1 Yoshima-Kogyodanchi
Iwaki-city, Fukushima, 970-1144 Japan
Phone: +81-246-36-8501 Fax: +81-246-36-8542
www.tungaloy.co.jp

Tungaloy America, Inc.

3726 N Ventura Drive, Arlington Heights, IL 60004, U.S.A.
Phone: +1-888-554-8394 Fax: +1-888-554-8392
www.tungaloyamerica.com

Tungaloy Canada

432 Elgin St. Unit 3, Brantford, Ontario N3S 7P7, Canada
Phone: +1-519-758-5779 Fax: +1-519-758-5791
www.tungaloyamerica.com

Tungaloy de Mexico S.A.

C Los Arellano 113, Parque Industrial Siglo XXI
Aguascalientes, AGS, Mexico 20290
Phone: +52-449-929-5410 Fax: +52-449-929-5411
www.tungaloyamerica.com

Tungaloy do Brasil Comércio de Ferramentas de Corte Ltda.

Rua dos Sabias N.104
13280-000 Vinhedo, São Paulo, Brazil
Phone: +55-19-38262757 Fax: +55-19-38262757
www.tungaloy.co.jp/br

Tungaloy Germany GmbH

An der Alten Ziegelei 1
D-40789 Monheim, Germany
Phone: +49-2173-90420-0 Fax: +49-2173-90420-19
www.tungaloy.de

Tungaloy France S.A.S.

ZA Courtaboeuf - Le Rio, 1 rue de la Terre de feu
F-91952 Courtaboeuf Cedex, France
Phone: +33-1-6486-4300 Fax: +33-1-6907-7817
www.tungaloy.fr

Tungaloy Italia S.r.l.

Via E. Andolfato 10
I-20126 Milano, Italy
Phone: +39-02-252012-1 Fax: +39-02-252012-65
www.tungaloy.it

Tungaloy Czech s.r.o

Tuřanka 115
CZ-627 00 Brno, Czech Republic
Phone: +420-532 123 391 Fax: +420-532 123 392
www.tungaloy.cz

Tungaloy Ibérica S.L.

C/Miquel Servet, 43B, Nau 7, Pol. Ind. Bufalvent
ES-08243 Manresa (BCN), Spain
Phone: +34 93 113 1360 Fax: +34 93 876 2798
www.tungaloy.es

Tungaloy Scandinavia AB

S:t Lars Väg 42A
SE-22270 Lund, Sweden
Phone: +46-462119200 Fax: +46-462119207
www.tungaloy.se

Tungaloy Rus, LLC

36-G Kostukova str.
308012 Belgorod, Russia
Phone: +7 4722 58 57 57 Fax: +7 4722 58 57 83
www.tungaloy.co.jp/ru

Tungaloy Polska Sp. z o.o.

ul. Genewska 24
03-963 Warszawa, Poland
Phone: +48-22-617-0890 Fax: +48-22-617-0890
www.tungaloy.co.jp/pl

Tungaloy U.K. Ltd

Hilton Hall Business Centre, Essington
Staffordshire, WV11 2BQ, UK
Phone: +44 121 309 0163 Fax: +44 121 270 9694
www.tungaloy.co.jp/uk salesinfo@tungaloyuk.co.uk

Tungaloy Hungary Kft

Erzsébet királyné útja 125
H-1142 Budapest, Hungary
Phone: +36 1 781-6846 Fax: +36 1 781-6866
www.tungaloy.co.jp/hu info@tungaloytools.hu

Tungaloy Turkey

Des San. Sit. Ticaret Merk 1. Cad No: 3 / 7
34776 Umraniye Istanbul, Turkey
Phone: +90 216 540 04 67 Fax: +90 216 540 04 97
www.tungaloy.co.jp/tr info@tungaloy.com.tr

Tungaloy Cutting Tool (Shanghai) Co.,Ltd.

Rm No 401 No.88 Zhabei, Jiangchang No.3 Rd
Shanghai 200436, China
Phone: +86-21-3632-1880 Fax: +86-21-3621-1918
www.tungaloy.co.jp/tcts

Tungaloy Cutting Tool (Thailand) Co.,Ltd.

11th Floor, Sorachai Bldg. 23/7, Soi Sukhumvit 63
Klongtonnue, Wattana, Bangkok 10110, Thailand
Phone: +66-2-714-3130 Fax: +66-2-714-3134
www.tungaloy.co.th

Tungaloy Singapore (Pte.), Ltd.

31 Kaki Bukit Road 3, #05-19 TechLink
Singapore 417818
Phone: +65-6391-1833 Fax: +65-6299-4557
www.tungaloy.co.jp/tspl

Tungaloy India Pvt. Ltd.

Unit#13, B wing, 8th Floor, Kamala Mills Compound
Trade World, Lower Parel (West), Mumbai - 4000 13. India
Phone: +91-22-6124-8804 Fax: +91-22-6124-8899
www.tungaloy.co.jp/in

Tungaloy Korea Co., Ltd

#1312, Byucksan Digital Valley 5-cha
Beotkkot-ro 244, Geumcheon-gu
153-788 Seoul, Korea
Phone: +82-2-2621-6161 Fax: +82-2-6393-8952
www.tungaloy.co.jp/krr

Tungaloy Malaysia Sdn Bhd

50 K-2, Kelana Mall, Jalan SS6/14, Kelana Jaya, 47301
Petaling Jaya, Selangor Darul Ehsan, Malaysia
Phone: +603-7805-3222 Fax: +603-7804-8563
www.tungaloy.co.jp/my

Tungaloy Australia Pty Ltd

Unit 308/33 Lexington Drive
Bella Vista NSW 2153, Australia
Phone: +612-9672-6844 Fax: +612-9672-6866
www.tungaloy.co.jp/au

Distributed by:

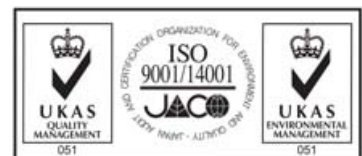

ISO 9001 certified
QC00J0056
Tungaloy Corporation

ISO 14001 certified
EC97J1123
Tungaloy Group
Japan site and Asian
production site
26/11/1997



18/10/1996

Produced from Recycled paper

Jun. 2012 (TJ)