

TAC Mill Series : Radial Milling Cutters

**NEW**

# ROUNDSPLIT

TRC / ERC type

**Overlapping Serrated Cutting Edge!**



## TRC / ERC type Radial milling cutters

### Features

#### 1 Anti-chatter cutter

Serrated cutting edge further breaks chips. This provides a very low cutting force and reduces chattering for long overhang applications.



Work material : S55C (200HB)  
 Cutting speed :  $V_c = 150$  m/min  
 Feed per tooth :  $f_z = 0.5$  mm/t  
 Depth of cut :  $a_p = 2$  mm  
 Width of cut :  $a_e = 50$  mm

#### Comparison of chip shape

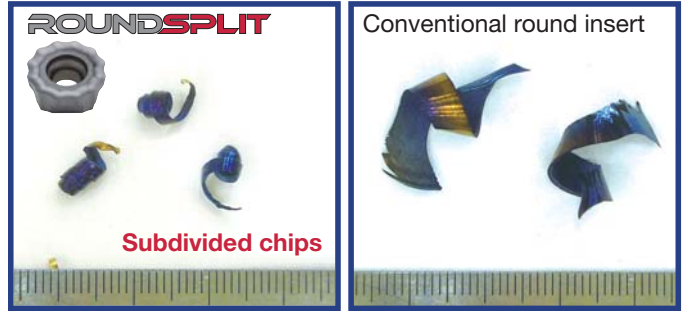

#### 2 Serrated and round inserts are available

Unique insert boss provides a tight fit and rigid clamping.

4 indexes per insert (Serration type)  
 8 indexes per insert (Regular round type)

These serrations are overlapped individually. When changing corners, please use the same insert slot. If you change slots, you cannot use all 4 or 8 cutting edges correctly.

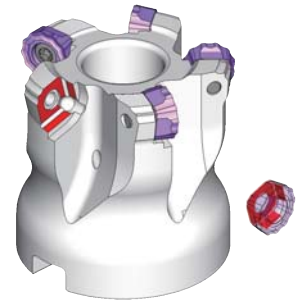

### Cutting performance

#### Comparison of application areas

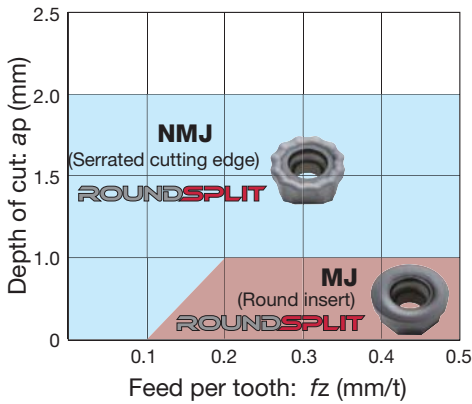

#### Comparison of spindle load

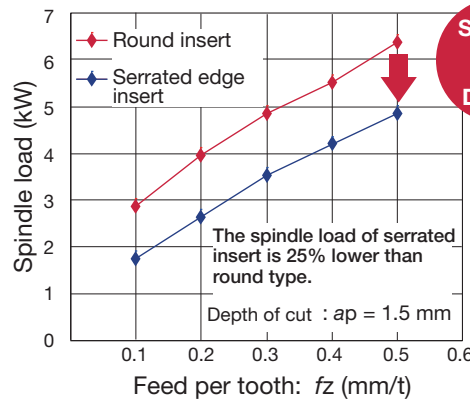

Work material : S55C (200HB)  
 Tool  $\varnothing$  :  $\varnothing 50$  mm (5 tooth)  
 Cutting speed :  $V_c = 150$  m/min  
 Width of cut :  $a_e = 50$  mm (Grooving)  
 Overhang : 238 mm ( $L/D = 4.76$ ) length

### Insert Specification

For general machining with serrated cutting edge

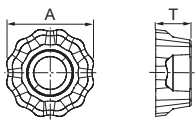

Fig. 1 NMJ

For general machining Round insert

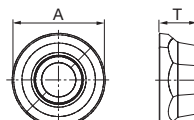

Fig. 2 MJ

For aluminium machining with serrated cutting edge

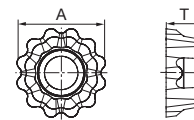
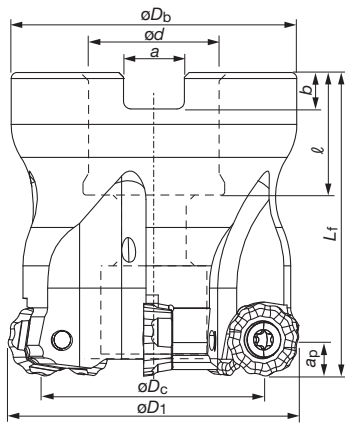

Fig. 3 NAJ

Cat. No.	Accuracy	Honing	Stock				Dimensions (mm)		Shape	Cutter
			Coated grades			Carbide	A	T		
			AH725	AH120	AH140					
RCMT1204EN-NMJ	M	with	●	●	●		12	4.8	Fig. 1	E/TRC12
RCMT1204EN-MJ	M	with	●	●	●		12	4.8	Fig. 2	
RCMT1204FN-NAJ	M	without				●	12	4.8	Fig. 3	
RCMT1606EN-NMJ	M	with	●	●	●		16	6.5	Fig. 1	E/TRC16
RCMT1606EN-MJ	M	with	●	●	●		16	6.5	Fig. 2	
RCMT1606FN-NAJ	M	without				●	16	6.5	Fig. 3	

# Cutter Body Specification

Bore type



Shank type

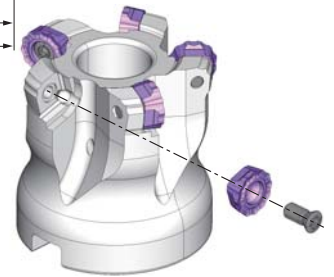
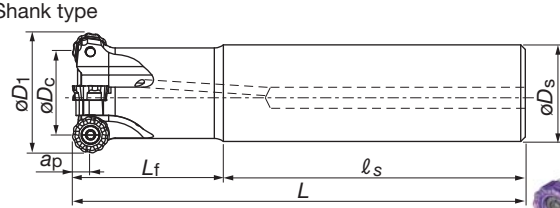

Max. depth of cut  
 RCMT12 type : Max.  $a_p$  = 6.0 mm  
 RCMT16 type : Max.  $a_p$  = 8.0 mm

Descriptions		Replacement parts Cat. No.		
Applicable cutter		TRC12R...	TRC16R050~100...	TRC16R125...
Clamping screw		<b>CSTB-4L090</b>	<b>CSTB-5L120</b>	<b>CSTB-5L120</b>
Wrench	Torx Bit	<b>BT15S</b>	<b>BT20S</b>	<b>BT20M</b>
	Grip	<b>H-TBS</b>	<b>H-TB</b>	<b>H-TB</b>
Mono block type substitution wrench		<b>T-15D</b>	<b>T-20D</b>	<b>T-20D</b>

## ■ Bore type

Cat. No.	Stock	No. of Inserts	Dimensions (mm)								Weight (kg)	Air hole	Cutter mounting screw	Inserts
			$\phi D_1$	$\phi D_c$	$\phi D_b$	$\phi d$	$\ell$	$L_f$	$b$	$a$				
TRC12R040M16.0-04	●	4	40	28	35	16	18	40	5.6	8.2	0.2	with	FSHM8-30H	RCMT1204*N-***
TRC12R050M22.0-05	●	5	50	38	47	22	20	50	6	10	0.4	with	CM10X30H	
TRC12R050M22.2-05	●	5	50	38	59	22.225	20	50	5	8	0.4	with	CM10X30H	
TRC12R063M22.0-06	●	6	63	51	59	22	20	50	6	10	0.7	with	CM10X30H	
TRC12R063M22.2-06	●	6	63	51	59	22.225	20	50	5	8	0.7	with	CM10X30H	
TRC12R080M31.7-07	●	7	80	68	76	31.75	32	63	8	12.7	1.5	with	CM16X40H	
TRC16R050M22.0-04	●	4	50	34	47	22	20	50	6	10	0.4	with	FSHM10-40H	RCMT1606*N-***
TRC16R050M22.2-04	●	4	50	34	47	22.225	20	50	5	8	0.4	with	FSHM10-40H	
TRC16R063M22.0-05	●	5	63	47	59	22	20	50	6	10	0.6	with	CM10X30H	
TRC16R063M22.2-05	●	5	63	47	59	22.225	20	50	5	8	0.7	with	CM10X30H	
TRC16R080M31.7-06	●	6	80	64	76	31.75	32	63	8	12.7	1.3	with	CM16X40H	
TRC16R100M31.7-07	●	7	100	84	96	31.75	32	63	8	12.7	1.6	with	CM16X40H	
TRC16R125M38.1-08	●	8	125	109	98	38.1	43	63	10	15.9	3.6	with	TMBA-M20H	

Descriptions		Replacement parts Cat. No.		
Applicable cutter		ERC12R...	ERC16R...	ERC16R040M32.0-02
Clamping screw		<b>CSTB-4L090</b>	<b>CSTB-5L120</b>	<b>CSTB-5L105</b>
Wrench (substitution)		<b>T-15DB (T-15D)</b>	<b>T-20DB (T-20D)</b>	<b>T-20DB (T-20D)</b>

## ■ Shank type

type	Cat. No.	Stock	No. of Inserts	Dimensions (mm)						Weight (kg)	Air hole	Inserts
				$\phi D_1$	$\phi D_c$	$\phi D_s$	$\ell_s$	$L_f$	$L$			
Standard	ERC12R032M32.0-03	●	3	32	20	32	80	70	150	0.8	with	RCMT1204*N-***
	ERC12R033M32.0-03	●	3	33	21	32	80	70	150	0.8	with	
	ERC12R040M32.0-04	●	4	40	28	32	100	50	150	0.8	with	
	ERC12R050M42.0-05	●	5	50	38	42	100	50	150	1.5	with	RCMT1606*N-***
	ERC16R040M32.0-02	●	2	40	24	32	100	50	150	0.8	with	
	ERC16R050M42.0-03	●	3	50	34	42	100	50	150	1.4	with	
Long	ERC12R032M32.0-03L	●	3	32	20	32	100	150	250	1.3	with	RCMT1204*N-***
	ERC12R033M32.0-03L	●	3	33	21	32	100	150	250	1.4	with	
	ERC12R040M32.0-04L	●	4	40	28	32	200	50	250	1.5	with	
	ERC12R050M42.0-05L	●	5	50	38	42	200	50	250	2.6	with	RCMT1606*N-***
	ERC16R040M32.0-02L	●	2	40	24	32	200	50	250	1.4	with	
	ERC16R050M42.0-03L	●	3	50	34	42	200	50	250	2.4	with	
Extra long	ERC12R032M32.0-03LL	●	3	32	20	32	120	180	300	1.6	with	RCMT1204*N-***
	ERC12R033M32.0-03LL	●	3	33	21	32	230	70	300	1.7	with	
	ERC12R040M32.0-04LL	●	4	40	28	32	250	50	300	1.8	with	
	ERC12R050M42.0-05LL	●	5	50	38	42	250	50	300	3.0	with	RCMT1606*N-***
	ERC16R040M32.0-02LL	●	2	40	24	32	250	50	300	1.7	with	
	ERC16R050M42.0-03LL	●	3	50	34	42	250	50	300	3.0	with	



## Standard cutting conditions

Work material	Brinell hardness HB	Grades	Cutting Speed Vc (m/min)	Feed per tooth fz (mm/t) each chipbreaker		
				NMJ	MJ	NAJ
Low carbon steels (S15C, SS400 etc.)	~ 200	<b>AH725</b>	100 - 160 - 220	0.17 - 0.25 - 0.3	0.2 - 0.5 - 0.7	-
High carbon steels (S45C, S55C etc.)	200 ~ 300		100 - 150 - 200			
Alloyed steels (SCM440, SCr415 etc.)	150 ~ 300		100 - 140 - 180			
Tool steels (SK, SKH etc.)	~ 300					
Stainless steels (SUS304, SUS316 etc.)	-	<b>AH140</b>	90 - 150 - 180	0.15 - 0.2 - 0.25	0.2 - 0.4 - 0.6	-
Grey cast irons (FC250, FC300 etc.)	150 ~ 250	<b>AH120</b>	140 - 180 - 250	0.17 - 0.25 - 0.3	0.2 - 0.5 - 0.7	-
Ductile cast irons (FCD400 etc.)						
Aluminium alloys (Si < 13%)	-	<b>KS15F</b>	500 - 800 - 1200	-	-	0.1 - 0.25 - 0.3
Aluminium alloys (Si ≥ 13%)	-		100 - 200 - 300			
Heat-resisting alloy (Inconel 718, Ti-6Al-4V etc.)	-	<b>AH725</b>	20 - 35 - 50	0.15 - 0.2 - 0.25	0.2 - 0.4 - 0.6	-

- To remove excessive chip accumulation use an air blast.
- When chips stick to the cutting edges (aluminium machining), use a water soluble cutting fluid.

- Cutting conditions are limited by machine power and material rigidity. When the cutting width or depth is large, set Vc and fz below the recommended values and check the machine vibration and spindle load.



# Tungaloy Corporation

### Tungaloy Corporation (Head office)

Solid Square, 580 Horikawa-cho, Saiwai-ku, Kawasaki City, 212-8503 Japan  
Phone: +81-44-548-9514 Fax: +81-44-548-9551  
<http://www.tungaloy.co.jp/>

### Tungaloy America, Inc.

Phone: +1-630-227-3700 Fax: +1-630-227-0690  
<http://www.tungaloyamerica.com/>

### Tungaloy Canada

Phone: +1-519-758-5779 Fax: +1-519-758-5791  
<http://www.tungaloyamerica.com/>

### Tungaloy de Mexico S.A.

Phone: +52-449-929-5410 Fax: +52-449-929-5411  
<http://www.tungaloyamerica.com/>

### Tungaloy do Brazil Comercio de Feramentas de Corte Ltda.

Phone: +55-19-38262757 Fax: +55-19-38262757  
<http://www.tungaloy.co.jp/>

### Tungaloy Germany GmbH

Phone: +49-2173-90420-0 Fax: +49-2173-90420-18  
<http://www.tungaloy-eu.com/>

### Tungaloy France S.a.r.l.

Phone: +33-1-6486-4300 Fax: +33-1-6907-7817  
<http://www.tungaloy-eu.com/>

### Tungaloy Italia S.p.A.

Phone: +39-02-252012-1 Fax: +39-02-252012-65  
<http://www.tungaloy-eu.com/>

### Tungaloy Czech s.r.o

Phone: +420-272652218 Fax: +420-234064270  
<http://www.tungaloy.co.jp/>

### Tungaloy Ibérica S.L.

Phone: +34 93 1131360 Fax: +34 93 1131361  
<http://www.tungaloy.co.jp/>

### Tungaloy Scandinavia AB

Phone: +46-462119201 Fax: +46-462119207  
<http://www.tungaloy.co.jp/>

### LLC Tungaloy Rus

Phone: +7-4722-33 97 23 Fax: +7-4722-33 97 23  
<http://www.tungaloy.co.jp/>

### Tungaloy Cutting Tool (Shanghai) Co.,Ltd.

Phone: +86-21-6247-0512 Fax: +86-21-6289-1302  
<http://www.tungaloy.co.jp/tcts>

### Tungaloy Cutting Tool (Thailand) Co.,Ltd.

Phone: +66-2-714-3130 Fax: +66-2-714-3134  
<http://www.tungaloy.co.th/>

### Tungaloy Singapore(Pte.),Ltd.

Phone: +65-6391-1833 Fax: +65-6299-4557  
<http://www.tungaloy.co.jp/tspl>

### India Branch

Phone: +91-11-4707-1111 Fax: +91-11-4707-1100  
<http://www.tungaloy.co.jp/tspl>

### Tungaloy Korea Co., Ltd

Phone: +82-2-6393-8930 Fax: +82-2-6393-8952  
<http://www.tungaloy.co.jp/>

Distributed by:



ISO 9001 certified  
QC00J0056  
18/10/1996  
Tungaloy Co.Ltd

ISO 14001 certified  
EC97J1123  
Japan site and Asian  
production site  
Tungaloy Group