

**Tungaloy**

Member IMC Group

Keeping the Customer First

Tungaloy Report No. 390-E

**MILLLINE** Shoulder milling cutter

**NEW**

**DORECC**

Remarkable productivity with tough cutting edges!



## Features

### ● Insert with tough cutting edges



### ● Improved productivity in high feed machining

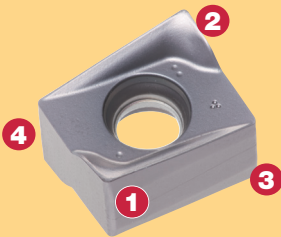

- Large rake angle reduces cutting forces.
- Double sided insert with 4 corners
- Available in 3 types of corner radius: 0.4, 0.8 and 1.6 mm

## Cutting performance

### ■ Comparison of chipping resistance

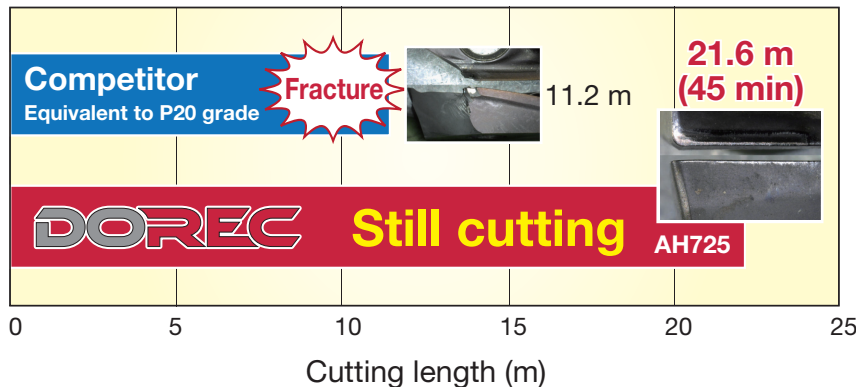

Tool diameter :  $\phi 25$  mm  
 Corner radius :  $r_{\epsilon} = 0.4$   
 Work material : S55C (200HB)  
 Machine : Vertical M/C, BT50  
 Cutting speed :  $V_c = 150$  m/min  
 Feed per tooth :  $f_z = 0.25$  mm/t  
 Depth of cut :  $a_p = 5.0$  mm  
 Width of cut :  $a_e = 12.5$  mm  
 Coolant : Dry  
 No. of inserts : Only used 1 insert

**Excellent stability even when high feed machining!**

### ■ Comparison of metal removal rate

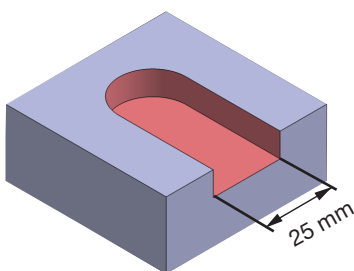

- Slotting
- Work material: S55C (200HB)
- Machine: Vertical M/C, BT50

Cutting conditions	DOREC	Competitor
Tool	EPQ11R025M25.0-02 ( $\phi 25$ mm, $z = 2$ )	$\phi 25$ mm, $z = 3$
Insert	LQMU110704PNER-MJ AH725	2 corner type insert, Grade equivalent to P30
Cutting speed: $V_c$ (m/min)	200	150
Feed per tooth: $f_z$ (mm/t)	0.15	0.1
Depth of cut: $a_p$ (mm)	8	5
Metal removal rate: $Q$ (cc/min)	<b>150</b>	70



# Milling cutter

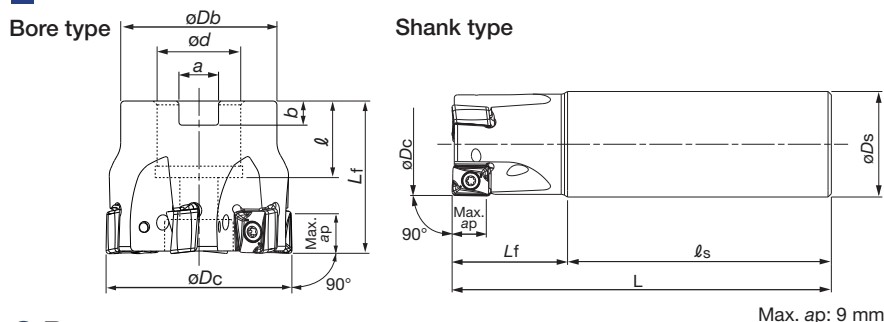

## Replacement parts

Descriptions		Cat. No.
Clamping screw		<b>CSTB-3.5L115</b>
Wrench	Torx bit	<b>BLDT10/S7</b>
	Grip	<b>SW6-SD</b>
Mono block type substitution wrench		<b>T-10D</b>

## Bore type

Cat. No.	Stock	No. of Inserts	Dimensions (mm)							Weight (kg)	Air hole	Center bolt
			$\phi Dc$	$\phi Db$	$\phi d$	$\ell$	$L_f$	$b$	$a$			
TPQ11R040M16.0E05	●	5	40	35	16	19	40	5.6	8.4	0.2	with	CM8x30H
TPQ11R050M22.0E06	●	6	50	41	22	20	40	6.3	10.4	0.4	with	CM10x30H
TPQ11R063M22.0E07	●	7	63	41	22	20	40	6.3	10.4	0.5	with	CM10x30H
TPQ11R080M25.4-10	●	10	80	46	25.4	26	50	6	9.5	1.0	with	CM12x30H
TPQ11R100M31.7-12	●	12	100	60	31.75	32	50	8	12.7	1.4	with	TMBA-M16H

## Shank type

Cat. No.	Stock	No. of Inserts	Dimensions (mm)					Weight (kg)	Air hole
			$\phi Dc$	$\phi Ds$	$\ell_s$	$L_f$	$L$		
EPQ11R025M25.0-02	●	2	25	25	80	35	115	0.3	with
EPQ11R032M32.0-03	●	3	32	32	80	35	115	0.7	with
EPQ11R040M32.0-04	●	4	40	32	80	35	115	0.8	with
EPQ11R050M32.0-05	●	5	50	32	80	40	120	0.9	with
EPQ11R063M32.0-06	●	6	63	32	80	40	120	1.1	with
EPQ11R080M32.0-07	●	7	80	32	80	40	120	1.4	with

# Inserts

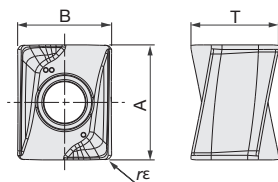

Cat. No.	Accuracy	Honing	Grades			Dimensions (mm)				Cutter
			Coated			A	B	T	$r_{\epsilon}$	
			AH725	AH120	AH140					
LQMU110704PNER-MJ	M	with	●	●	●	11.0	9.0	8.3	0.4	EPQ11R TPQ11R
LQMU110708PNER-MJ	M	with	●	●	●	11.0	9.0	8.3	0.8	
LQMU110716PNER-MJ	M	with	●	●	●	11.0	9.0	8.3	1.6	

● : Stocked items

# Standard cutting conditions

Work Materials	Hardness HB	Grades	Cutting Speed Vc (m/min)	Feed per tooth fz (mm/t)
Low carbon steel (S15C, SS400 etc.)	~ 200	<b>AH725</b>	180 (100-250)	0.18 (0.10-0.25)
High carbon steel (S45C, S55C etc.)	200 ~ 300		150 (100-230)	0.15 (0.10-0.20)
Alloy steel (SCM440, SCr415 etc.)	150 ~ 300		120 (100-180)	
Tool steel (SK, SKH etc.)	~ 300			
Stainless steel (SUS304, SUS316 etc.)	-	<b>AH140</b>	150 (90-180)	0.18 (0.10-0.25)
Grey cast iron (FC250, FC300 etc.)	150 ~ 250	<b>AH120</b>	180 (140-250)	0.18 (0.10-0.25)
Ductile cast iron (FCD400 etc.)				
Superalloys (Inconel 718, Ti-6Al-4V etc.)	-	<b>AH725</b>	35 (20-50)	0.14 (0.08-0.20)

- To remove excessive chip accumulation use an air blast.
- When cutting an interrupted surface or a casting skin, the feed (fz) should be reduced to the lower recommended value shown in the above table.

- Cutting conditions are limited by machine power, work piece rigidity, and spindle output. When the cutting width, depth or overhang length is large, set Vc and fz to the lower recommended values and check the machine power and vibration.

# Practical Examples

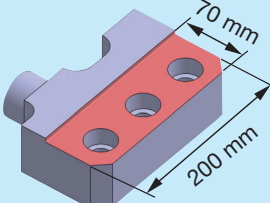
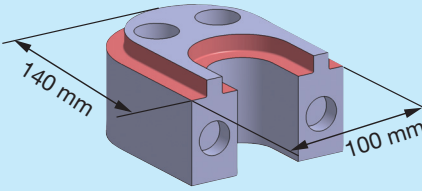
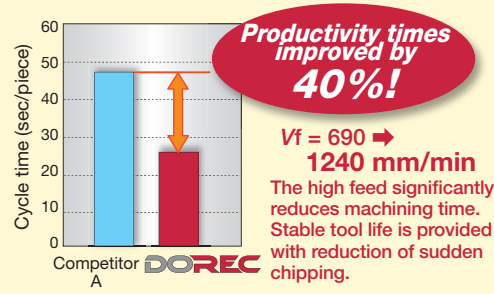
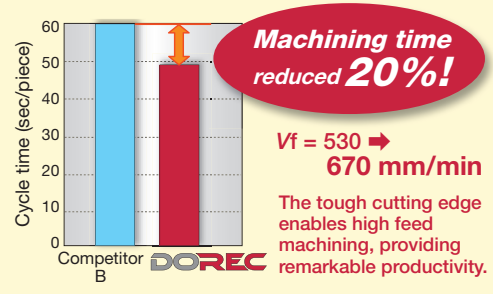
Part of workpiece		Machine part (block)	Machine parts
Milling cutter		TPQ11R050M22.0E06 (ø50, z = 6)	EPQ11R032M32.0-03 (ø32, z = 3)
Insert		LQMU110708PNER-MJ	LQMU110708PNER-MJ
Grade		AH725	AH725
Work material		S55C (200HB)	SCM440 (32HRC)
			
Cutting conditions	Cutting speed: Vc (m/min)	180	150
	Feed per tooth: fz (mm/t)	0.18	0.15
	Depth of cut: ap (mm)	5	5 x 2 passes
	Width of cut: ae (mm)	35 x 2 passes	10
	Method of machining	Shoulder milling	Shoulder milling
	Coolant	Dry	Dry
	Machine	Vertical M/C, BT50	Vertical M/C, BT40
Results			



# Tungaloy Corporation

## Tungaloy Corporation (Head office)

11-1 Yoshima-Kogyodanchi  
Iwaki-city, Fukushima, 970-1144 Japan  
Phone: +81-246-36-8501 Fax: +81-246-36-8542  
<http://www.tungaloy.co.jp/>

## Tungaloy America, Inc.

Phone: +1-888-554-8394 Fax: +1-888-554-8392  
<http://www.tungaloyamerica.com/>

## Tungaloy Canada

Phone: +1-519-758-5779 Fax: +1-519-758-5791  
<http://www.tungaloyamerica.com/>

## Tungaloy de Mexico S.A.

Phone: +52-449-929-5410 Fax: +52-449-929-5411  
<http://www.tungaloyamerica.com/>

## Tungaloy do Brasil Comércio de Ferramentas de Corte Ltda.

Phone: +55-19-38262757 Fax: +55-19-38262757  
<http://www.tungaloy.co.jp/br/>

## Tungaloy Germany GmbH

Phone: +49-2173-90420-0 Fax: +49-2173-90420-19  
<http://www.tungaloy.de>

## Tungaloy France S.A.S.

Phone: +33-1-6486-4300 Fax: +33-1-6907-7817  
<http://www.tungaloy-eu.com/>

## Tungaloy Italia S.r.l.

Phone: +39-02-252012-1 Fax: +39-02-252012-65  
<http://www.tungaloy-eu.com/>

## Tungaloy Czech s.r.o

Phone: +420 532 123 391 Fax: +420 532 123 392  
<http://www.tungaloy.co.jp/cz/>

## Tungaloy Ibérica S.L.

Phone: +34 93 1131360 Fax: +34 93 1131361  
<http://www.tungaloy.co.jp/es/>

## Tungaloy Scandinavia AB

Phone: +46-462119200 Fax: +46-462119207  
<http://www.tungaloy.co.jp/se/>

## Tungaloy Rus, LLC

Phone: +7 4722 58 57 57 Fax: +7 4722 58 57 83  
<http://www.tungaloy.co.jp/ru/>

## Tungaloy Polska Sp. z o.o

Phone: +48-22-617-0890 Fax: +48-22-617-0890  
<http://www.tungaloy.co.jp/pl/>

## Tungaloy UK Ltd

Phone: +44 121 244 3064 Fax: +44 121 270 9694  
<http://www.tungaloy.co.jp/uk>

## Tungaloy Cutting Tool (Shanghai) Co.,Ltd.

Phone: +86-21-3632-1880 Fax: +86-21-3621-1918  
<http://www.tungaloy.co.jp/tcts/>

## Tungaloy Cutting Tool (Thailand) Co.,Ltd.

Phone: +66-2-714-3130 Fax: +66-2-714-3134  
<http://www.tungaloy.co.th/>

## Tungaloy Singapore (Pte.),Ltd.

Phone: +65-6391-1833 Fax: +65-6299-4557  
<http://www.tungaloy.co.jp/tsp/>

## Tungaloy India Pvt. Ltd.

Phone: +91-22-6124-8804 Fax: +91-22-6124-8899  
<http://www.tungaloy.co.jp/in/>

## Tungaloy Korea Co., Ltd

Phone: +82-2-6393-8930 Fax: +82-2-6393-8952  
<http://www.tungaloy.co.jp/kr/>

## Tungaloy Malaysia Sdn Bhd

Phone: +603-7805-3222 Fax: +603-7804-8563  
<http://www.tungaloy.co.jp/my/>

## Tungaloy Australia Pty Ltd

Phone: +612-9672-6844 Fax: +612-9672-6866  
<http://www.tungaloy.co.jp/au>

Distributed by:



ISO 9001 certified  
QC00J0056  
Tungaloy Corporation

18/10/1996

ISO 14001 certified  
EC97J1123  
Tungaloy Group  
Japan site and Asian  
production site  
26/11/1997