

輔助零件類

PT01~PT59



SMOOTH BALL END BOLT SERRATED BALL END BOLT KNURLED NUT FLANGE NUT EXCESSIVE NUT

PT01

平面動向鋼珠螺桿支持件 SMOOTH BALL END BOLT



- 材質：本體 S45C，鋼珠 SUJ2
- 熱處理：本體 HRC 28°~32°，鋼珠 HRC 62°
- 表面：染黑處理
- 用途：適用於支持或夾持工件之斜面上，使其不易變形

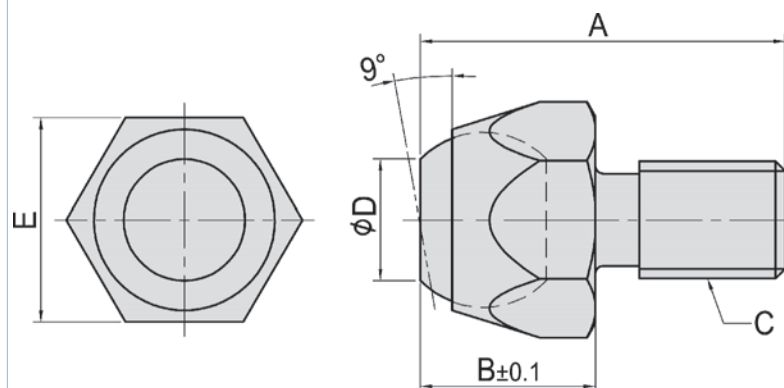

MODEL NO.	A	B	C	D	E	kg
PT01-0610	21	10	M6x1.00	6	10	0.012
PT01-0814	25	12	M8x1.25	8	14	0.015
PT01-1017	30	16	M10x1.50	10	17	0.025
PT01-1222	35	22	M12x1.75	12	22	0.070
PT01-1627	42	26	M16x2.00	14	27	0.140
PT01-2036	55	27	M20x2.50	14	36	0.280
PT01-2436	65	32	M24x2.00	18	36	0.560
PT01-3046	80	35	M30x2.00	21	46	0.880

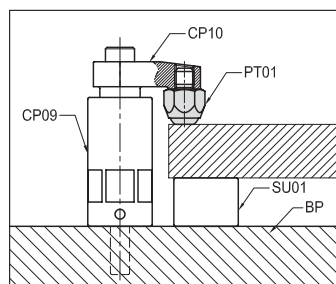

PT02

齒面動向鋼珠螺桿支持件 SERRATED BALL END BOLT



- 材質：本體 S45C，鋼珠 SUJ2
- 熱處理：本體 HRC 28°~32°，鋼珠 HRC 62°
- 表面：染黑處理
- 用途：適用於支持或夾持工件之斜面上，使其不易變形

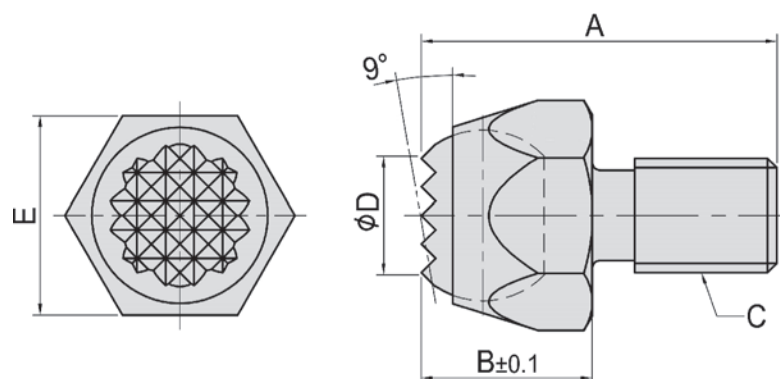

MODEL NO.	A	B	C	D	E	kg
PT02-0610	21	10	M6x1.00	6	10	0.012
PT02-0814	25	12	M8x1.25	8	14	0.015
PT02-1017	30	16	M10x1.50	10	17	0.025
PT02-1222	35	22	M12x1.75	12	22	0.070
PT02-1627	42	26	M16x2.00	14	27	0.140
PT02-2036	55	27	M20x2.50	14	36	0.280
PT02-2436	65	32	M24x2.00	18	36	0.560
PT02-3046	80	35	M30x2.00	21	46	0.880

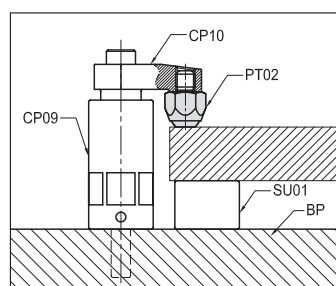

PT03

止動螺帽 KNURLED NUT

- 材質：S45C
- 熱處理：HRC 30°~35°
- 表面：染黑處理
- 用途：可用於固定螺栓，使其不易鬆動

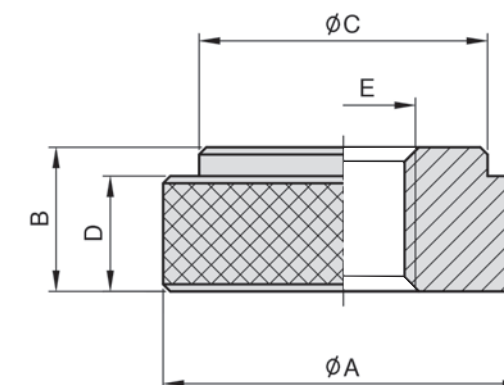

MODEL NO.	A	B	C	D	E	kg
PT03-0820	20	8	16	6	M 8	0.015
PT03-1025	25	10	20	8	M10	0.030
PT03-1228	28	12	24	10	M12	0.040
PT03-1630	30	12	25	10	M16	0.045

PT04

法蘭螺帽 FLANGE NUT



- 材質：S45C
- 熱處理：HRC 30°~35°
- 表面：染黑處理

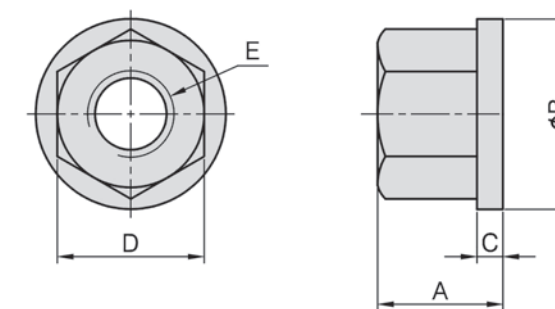

MODEL NO.	A	B	C	D	E	kg
PT04-0812	9	17	3	12	M 8	0.010
PT04-1017	13	22	3	17	M10	0.020
PT04-1219	17	28	4	19	M12	0.040
PT04-1422	17	28	4	22	M14	0.040
PT04-1624	20	32	5	24	M16	0.060
PT04-1827	20	35	5	27	M18	0.070
PT04-2030	25	40	6	30	M20	0.110
PT04-2232	28	45	6	32	M22	0.150
PT04-2436	28	47	6	36	M24	0.185

PT05

連結螺帽 EXTENSION NUT

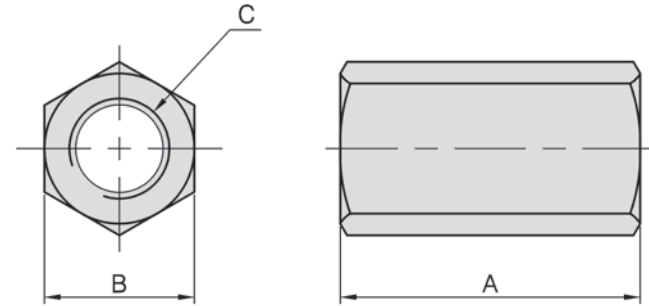

- 材質：S45C
- 熱處理：HRC 30°~35°
- 表面：染黑處理
- 用途：連結螺桿加長之用

MODEL NO.	A	B	C	kg
PT05-0813	22	14	M 8	0.020
PT05-1017	30	17	M10	0.030
PT05-1219	36	19	M12	0.046
PT05-1422	42	22	M14	0.065
PT05-1624	48	24	M16	0.110
PT05-1827	54	27	M18	0.150
PT05-2030	60	30	M20	0.220
PT05-2232	66	32	M22	0.350
PT05-2436	72	36	M24	0.350

PT06

T型螺帽 T-SLOT NUT



- 材質：S45C
- 熱處理：HRC 30°~35°
- 表面：染黑處理

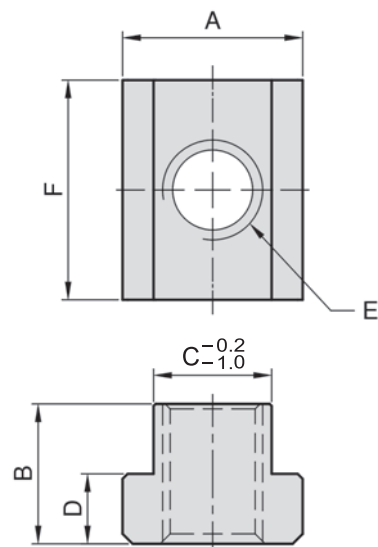

MODEL NO.	A	B	C	D	E	F	kg
PT06-1008	15.0	13.0	10.0	6.0	M 8	22	0.020
PT06-1210	18.0	14.0	12.0	7.0	M10		0.022
PT06-1410	22.0	16.0	14.0	8.0	M10	28	0.050
PT06-1412					M12		0.048
PT06-1612	25.0	16.0	16.0	8.0	M12	28	0.060
PT06-1614					M14		0.057
PT06-1810	28.0	20.0	18.0	10.5	M10	30	0.090
PT06-1812				M12			
PT06-1814				M14			
PT06-1816	28.0	20.0		10.5	M16	30	0.090
PT06-2016	32.0	19.0	20.0	11.9	M16	30	0.098
PT06-2018	32.0	25.0		14.0	M18	38	0.110
PT06-2218	36.0	25.0	22.0	14.0	M18	38	0.178
PT06-2220					M20		0.190
PT06-2418	38.0	25.0	24.0	14.0	M18	38	0.184
PT06-2420					M20		0.250
PT06-2620	41.3	25.0	26.0	15.8	M20	44	0.250
PT06-2622					M22		0.240
PT06-2822	44.0	28.5	28.0	17.5	M22	50	0.330
PT06-2824					M24		0.312

PT07

標準螺桿 CLAMPING STUD



- 材質：S45C
- 熱處理：HRC 22°~28°
- 表面：染黑處理

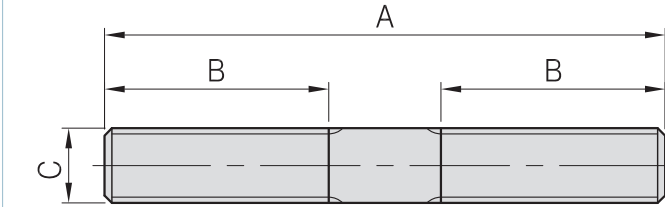

MODEL NO.	A	B	C	kg	
PT07-08050	50	22	M8 P=1.25	0.020	
PT07-08075	75			0.030	
PT07-08100	100	38		0.040	
PT07-08125	125			0.050	
PT07-08150	150	50		0.060	
PT07-08175	175			0.070	
PT07-08200	200			0.080	
PT07-08250	250			0.098	
PT07-10050	50	22		M10 P=1.5	0.030
PT07-10075	75				30
PT07-10100	100	38	0.055		
PT07-10125	125		0.070		
PT07-10150	150	50	0.090		
PT07-10175	175		0.108		
PT07-10200	200		0.123		
PT07-10250	250		0.154		
PT07-12050	50	22	M12 P=1.75		0.040
PT07-12075	75				30
PT07-12100	100	38		0.080	
PT07-12125	125			0.100	
PT07-12150	150	50		0.125	
PT07-12175	175			0.155	
PT07-12200	200			0.160	
PT07-12300	300			80	0.240
PT07-14050	50	22		M14 P=2.0	0.060
PT07-14075	75				30
PT07-14100	100	38	0.120		
PT07-14125	125		0.150		
PT07-14150	150	50	0.180		
PT07-14175	175		0.210		
PT07-14200	200		0.240		
PT07-16050	50		22		M16 P=2.0
PT07-16075	75	30			
PT07-16100	100	38	0.145		
PT07-16125	125		0.180		
PT07-16150	150	50	0.230		
PT07-16175	175		0.276		
PT07-16200	200		0.290		
PT07-16250	250		65	0.350	
PT07-16300	300	80	0.450		
PT07-16400	400	100	0.580		
PT07-16500	500		0.700		

MODEL NO.	A	B	C	kg	
PT07-18050	50	22	M18 P=2.5	0.100	
PT07-18075	75			30	0.150
PT07-18100	100	38		0.200	
PT07-18125	125			0.220	
PT07-18150	150	50		0.300	
PT07-18175	175			0.320	
PT07-18200	200			65	0.360
PT07-18300	300			80	0.600
PT07-20050	50	22		M20 P=2.5	0.125
PT07-20075	75				30
PT07-20100	100	38	0.230		
PT07-20125	125		0.275		
PT07-20150	150	50	0.360		
PT07-20175	175		0.437		
PT07-20200	200		65		0.450
PT07-20250	250		80		0.550
PT07-20300	300	80	0.700		
PT07-20400	400	100	0.880		
PT07-20500	500		1.100		
PT07-22050	50	22	M22 P=2.5	0.150	
PT07-22075	75			30	0.223
PT07-22100	100	38		0.300	
PT07-22125	125			0.373	
PT07-22150	150	50		0.448	
PT07-22175	175			0.522	
PT07-22200	200			65	0.597
PT07-22250	250			80	0.746
PT07-22300	300	80		0.895	
PT07-22400	400			1.194	
PT07-22500	500	100	1.492		
PT07-24050	50	22	M24 P=3.0	0.177	
PT07-24075	75			30	0.266
PT07-24100	100	38		0.355	
PT07-24125	125			0.443	
PT07-24150	150	50		0.533	
PT07-24175	175			0.620	
PT07-24200	200			65	0.710
PT07-24250	250			80	0.880
PT07-24300	300	80		1.065	
PT07-24400	400			1.420	
PT07-24500	500	100	1.775		

PT08

定位T型螺帽 T-SLOT NUT(GROUND)



- 材質：本體 S45C
- 熱處理：HRC 30°~35°
- 用途：使用於T形溝基板或T形溝基座，與治具零件作定位用。

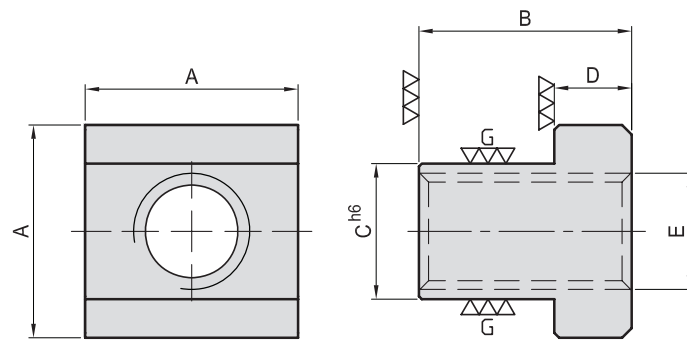

MODEL NO.	A	B	C	D	E	kg
PT08-1214	22	22	14	8	M12	0.045
PT08-1618	28	30	18	10	M16	0.080

PT09

單眼螺桿 EYEBOLT



- 材質：SCM220
- 熱處理：HRC 30°~35°
- 用途：與 PT28 配合使用
- 特長：拆裝方便，可任其發揮。

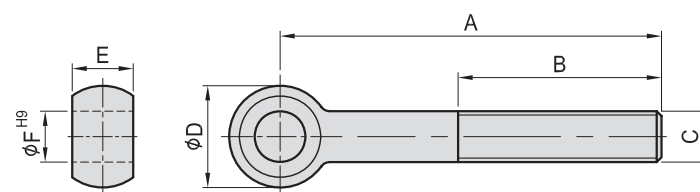

MODEL NO.	A	B	C	D	E	F	kg
PT09-10075	75	40	M10	20	12	10	0.060
PT09-10100	100						0.080
PT09-12075	75	50	M12	25	14	12	0.095
PT09-12100	100						0.120
PT09-16125	125	60	M16	32	17	16	0.250
PT09-16150	150						0.300
PT09-20125	125	60	M20	40	22	20	0.400
PT09-20150	150						0.485

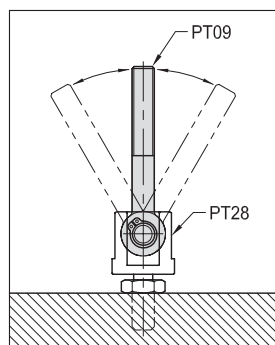

- 材質：SCM440
- 熱處理：HRC 45°
- 用途：用於基板與MC工作台T形溝作定位用

PT10

定位梢 LOCATING KEY

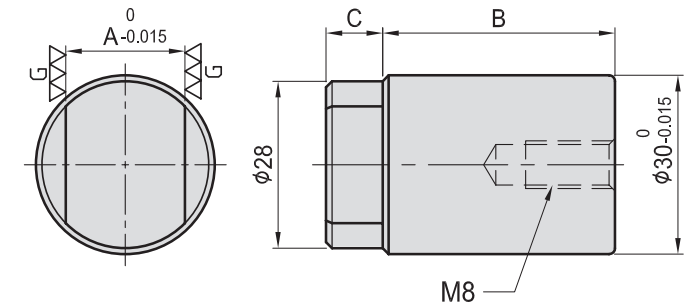

MODEL NO.	A	B	C	kg
PT10-1410	14	49	10.0	0.032
PT10-1815	18		15.0	0.033
PT10-2009	20	39	9.5	0.028
PT10-2010	20	49	10.0	0.033
PT10-2015			15.0	0.034

PT11

定位梢 THREADED DOWEL PINS



- 材質：SCM440
- 熱處理：HRC 45°
- 用途：基板或基座與治具零件作定位用

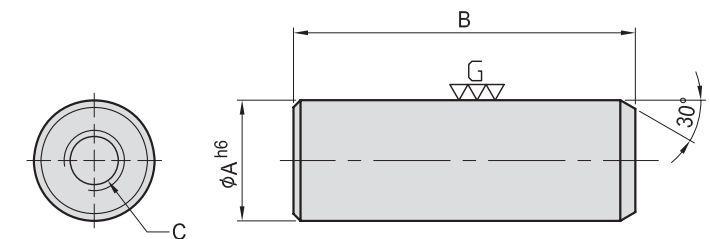

MODEL NO.	A	B	C	kg
PT11-0825	8	25	M4	0.010
PT11-1030	10	30	M5	0.015
PT11-1234	12	34	M6	0.030
PT11-1642	16	42		0.060
PT11-2047	20	47	M8	0.100
PT11-2549	25	49		0.160

PT12

頂桿用端點零件 JACK SCREW TIP

PT12A-3028



NW : 70g

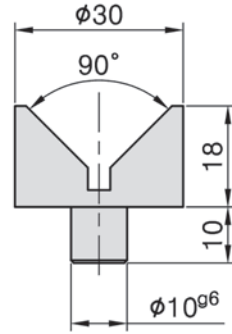

PT12B-3020



NW : 50g

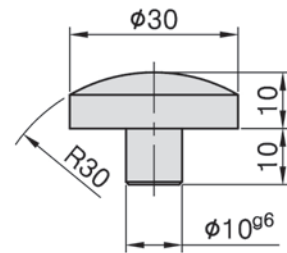

PT12C-3028



NW : 60g

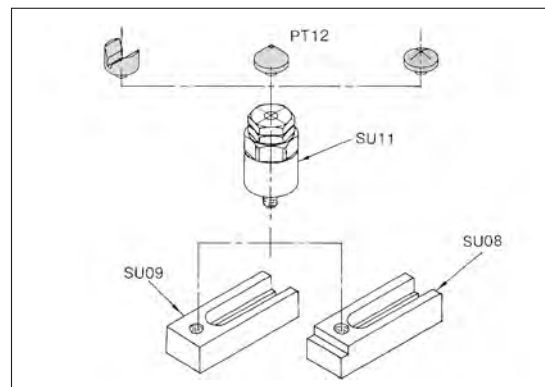
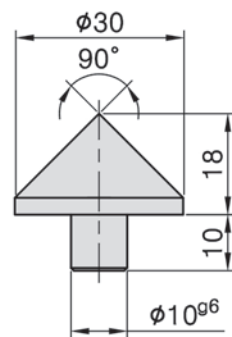

- 材質：SCM440
- 熱處理：HRC 60°
- 表面：染黑處理
- 用途：與SU11配合，作支持工件用。

PT13 齒面支持件
SERRATED END



PT14 平面支持件
FLAT END



PT15 圓頭支持件
ROUND END



PT13-15

支持件 GRIPPER NUT

- 材質：SCM440
- 熱處理：HRC 60°
- 表面：染黑處理

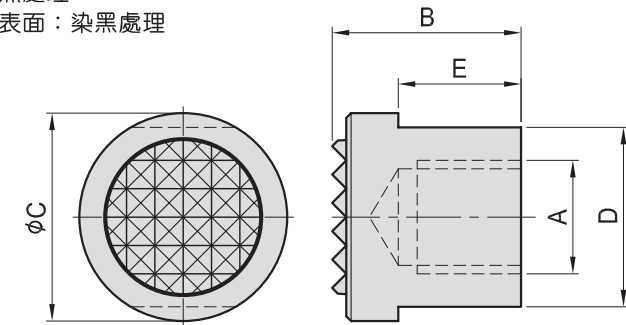

- 齒盤
- 材質：SKH9
 - 熱處理：HRC 60°

MODEL NO.	A	B	C	D	E	kg
PT13-1220	M12	20	22	19	13	0.043
PT13-1625	M16	25	28	24	16	0.080

- 齒盤
- 材質：錫鋼

MODEL NO.	A	B	C	D	E	kg
PT13-1220-K	M12	20	22	19	13	0.043
PT13-1625-K	M16	25	28	24	16	0.080

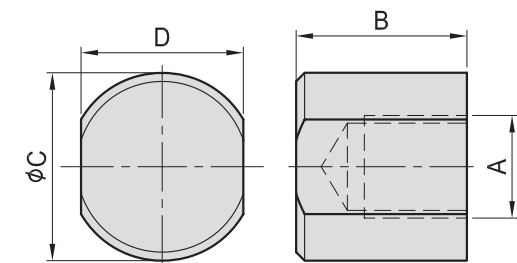

MODEL NO.	A	B	C	D	kg
PT14-1220	M12	20	22	19	0.043
PT14-1625	M16	25	28	24	0.076

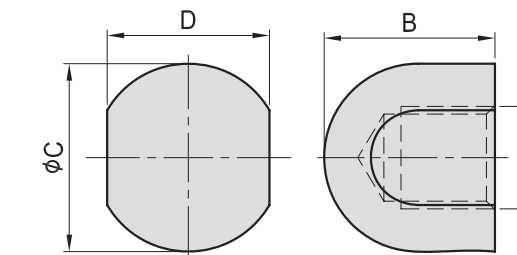

MODEL NO.	A	B	C	D	kg
PT15-1220	M12	20	22	19	0.042
PT15-1625	M16	25	28	24	0.063

BP

BPA

BC

CP

SU

PT

SVF

ALV

OK-
VISE

MITEE-
BITE

JER-
GENS

其他類

技術
資料

PT16

動向鋼珠螺桿 SWIVEL CLAMPING SCREW

PT16A 圓球型 ROUND END

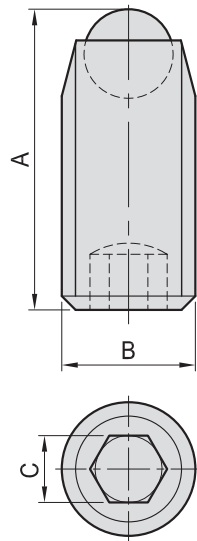

- 材質：本體 SCM21 鋼珠 SUJ2
- 熱處理：本體 HRC 28°~32°，鋼珠 HRC 62°
- 用途：配合治具零件的組成，可做夾持或支持之用
- 特長：點接觸，工件不易變形

MODEL NO.	A	B	C	max (KN)	g
PT16A-0408	8.0	M4	2	4	0.6
PT16A-0410	10.0				0.7
PT16A-0412	12.0				0.8
PT16A-0416	16.0				1.1
PT16A-0510	10.0	M5	2.5	5	1.0
PT16A-0512	12.0				1.3
PT16A-0516	16.0				1.7
PT16A-0520	20.0				2.3
PT16A-0525	25.0				2.9
PT16A-0610	10.8	M6	3	9	1.5
PT16A-0615	13.5				2.4
PT16A-0616	16.8				2.4
PT16A-0620	20.8				3.0
PT16A-0625	23.5				3.8
PT16A-0812	12.0	M8	4	15	3.2
PT16A-0816	17.2				4.1
PT16A-0820	20.0				5.8
PT16A-0825	26.2				7.3
PT16A-0830	30.0				9.0
PT16A-1014	15.0	M10	5	20	5.0
PT16A-1015	16.0				6.7
PT16A-1020	21.0				8.7
PT16A-1025	26.0				11.2
PT16A-1030	31.0				13.7
PT16A-1035	36.0	16.2			
PT16A-1040	41.0	18.7			
PT16A-1218	18.2	M12	6	30	10.0
PT16A-1220	23.2				12.5
PT16A-1230	31.2				20.0
PT16A-1240	41.2				30.0
PT16A-1250	51.2				40.0
PT16A-1625	25.6	M16	8	60	28.0
PT16A-1635	35.6				40.0
PT16A-1645	45.6				45.0
PT16A-1655	55.6				55.0
PT16A-1665	65.6				65.0
PT16A-2030	32.0	M20	10	90	54.0
PT16A-2040	42.0				74.0
PT16A-2050	52.0				94.0
PT16A-2060	62.0				120.0
PT16A-2435	37.0	M24	12	120	90.0
PT16A-2450	52.0				130.0
PT16A-2480	82.0				235.0

PT16B 平面型 FLAT END

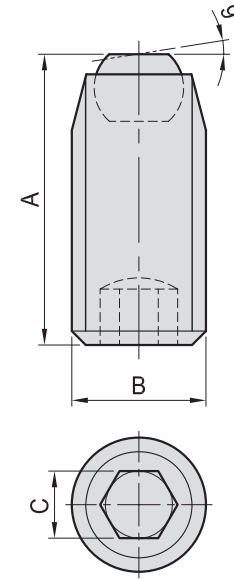

PT16C 齒型 SERRATED END

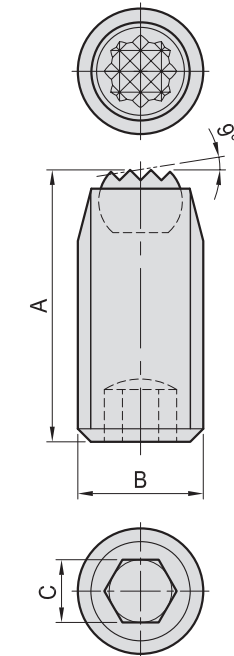

MODEL NO.	MODEL NO.	A	B	C	max (KN)	g
PT16B-0610	PT16C-0610	10.3	M6	3	9	1.5
PT16B-0615	PT16C-0615	13.0				2.4
PT16B-0616	PT16C-0616	16.3				2.4
PT16B-0620	PT16C-0620	20.3				3.0
PT16B-0625	PT16C-0625	23.0	3.8			
PT16B-0812	PT16C-0812	11.2	M8	4	15	3.2
PT16B-0816	PT16C-0816	16.4				4.1
PT16B-0820	PT16C-0820	19.2				5.8
PT16B-0825	PT16C-0825	25.4				7.3
PT16B-0830	PT16C-0830	29.2				9.0
PT16B-1014	PT16C-1014	14.0	M10	5	20	5.0
PT16B-1015	PT16C-1015	15.0				6.7
PT16B-1020	PT16C-1020	20.0				8.7
PT16B-1025	PT16C-1025	25.0				11.2
PT16B-1030	PT16C-1030	30.0				13.7
PT16B-1035	PT16C-1035	35.0	16.2			
PT16B-1040	PT16C-1040	40.0	18.7			
PT16B-1218	PT16C-1218	17.0	M12	6	30	10.0
PT16B-1220	PT16C-1220	22.0				12.5
PT16B-1230	PT16C-1230	30.0				20.0
PT16B-1240	PT16C-1240	40.0				30.0
PT16B-1250	PT16C-1250	50.0				40.0
PT16B-1625	PT16C-1625	24.0	M16	8	60	28.0
PT16B-1635	PT16C-1635	34.0				40.0
PT16B-1645	PT16C-1645	44.0				45.0
PT16B-1655	PT16C-1655	54.0				55.0
PT16B-1665	PT16C-1665	64.0				65.0
PT16B-2030	PT16C-2030	30.0	M20	10	90	54.0
PT16B-2040	PT16C-2040	40.0				74.0
PT16B-2050	PT16C-2050	50.0				94.0
PT16B-2060	PT16C-2060	60.0				120.0
PT16B-2435	PT16C-2435	35.0	M24	12	120	90.0
PT16B-2450	PT16C-2450	50.0				130.0
PT16B-2480	PT16C-2480	80.0				235.0

BP

BPA

BC

CP

SU

PT

SVF

ALV

OK-
VISE

MITEE-
BITE

JER-
GENS

其他類

技術
資料

PT17

動向鋼珠螺桿 SWIVEL SHOULDER CLAMPING SCREW

PT17A 圓球型 ROUND END

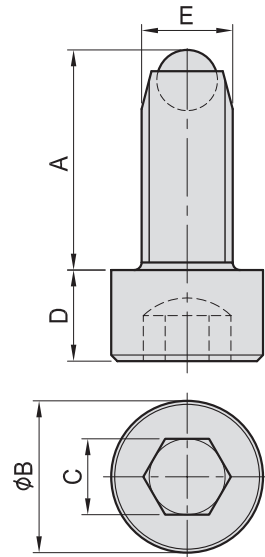

- 材質：本體 SCM21 鋼珠 SUJ2
- 熱處理：本體 HRC 28°~32°，鋼珠 HRC 62°
- 用途：配合治具零件的組成，可作夾持或支持之用
- 特長：點接觸，工件不易變形

MODEL NO.	A	B	C	D	E	max (KN)	g
PT17A-0615	14.5						5.3
PT17A-0625	23.5	10	5	6	M 6	9	7.4
PT17A-0635	33.5						9.5
PT17A-0820	18.7						13.5
PT17A-0830	28.7	13	6	8	M 8	15	20.0
PT17A-0840	38.7						24.0
PT17A-0850	50.7						30.0
PT17A-1025	25.0						26.0
PT17A-1040	40.0	16	8	10	M10	20	34.0
PT17A-1060	60.0						46.0
PT17A-1230	31.2						40.0
PT17A-1245	46.2	18	10	12	M12	30	50.0
PT17A-1265	66.2						70.0
PT17A-1280	81.2						83.0
PT17A-1640	40.6						90.0
PT17A-1650	50.6	24	14	16	M16	60	110.0
PT17A-1665	65.6						130.0
PT17A-1690	90.6						170.0
PT17A-20050	52.0	30	17	20	M20	90	185.1
PT17A-20080	82.0						256.4
PT17A-20100	102.0						301.2
PT17A-24060	62.0	36	19	24	M24	120	324.8
PT17A-24090	92.0						283.5
PT17A-24120	122.0						351.0

PT17B 平面型 FLAT END

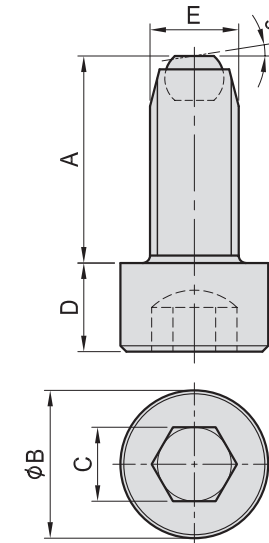

PT17C 齒型 SERRATED END

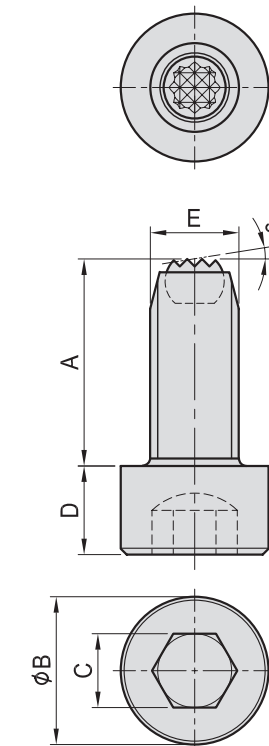

MODEL NO.	A	B	C	D	E	max (KN)	g
PT17B-0615	14						5.3
PT17B-0625	23	10	5	6	M 6	9	7.4
PT17B-0635	33						9.5
PT17B-0820	18						13.5
PT17B-0830	28	13	6	8	M 8	15	20.0
PT17B-0840	38						24.0
PT17B-0850	50						30.0
PT17B-1025	24						26.0
PT17B-1040	39	16	8	10	M10	20	34.0
PT17B-1060	59						46.0
PT17B-1230	30						40.0
PT17B-1245	45	18	10	12	M12	30	50.0
PT17B-1265	65						70.0
PT17B-1280	80						83.0
PT17B-1640	39						90.0
PT17B-1650	49	24	14	16	M16	60	110.0
PT17B-1665	64						130.0
PT17B-1690	89						170.0
PT17B-20050	50	30	17	20	M20	90	185.1
PT17B-20080	80						256.4
PT17B-20100	100						301.2
PT17B-24060	60	36	19	24	M24	120	324.8
PT17B-24090	90						283.5
PT17B-24120	120						351.0

MODEL NO.	A	B	C	D	E	max (KN)	g
PT17C-0615	14						5.3
PT17C-0625	23	10	5	6	M 6	9	7.4
PT17C-0635	33						9.5
PT17C-0820	18						13.5
PT17C-0830	28	13	6	8	M 8	15	20.0
PT17C-0840	38						24.0
PT17C-0850	50						30.0
PT17C-1025	24						26.0
PT17C-1040	39	16	8	10	M10	20	34.0
PT17C-1060	59						46.0
PT17C-1230	30						40.0
PT17C-1245	45	18	10	12	M12	30	50.0
PT17C-1265	65						70.0
PT17C-1280	80						83.0
PT17C-1640	39						90.0
PT17C-1650	49	24	14	16	M16	60	110.0
PT17C-1665	64						130.0
PT17C-1690	89						170.0
PT17C-20050	50	30	17	20	M20	90	185.1
PT17C-20080	80						256.4
PT17C-20100	100						301.2
PT17C-24060	60	36	19	24	M24	120	324.8
PT17C-24090	90						283.5
PT17C-24120	120						351.0

BP

BPA

BC

CP

SU

PT

SVF

ALV

OK-
VISE

MITEE-
BITE

JER-
GENS

其他類

技術
資料

PT18

齒型螺桿 GRIPPER SCREW



- 材質：本體 SCM435
- 熱處理：本體 HRC 32°~38°
- 表面：染黑處理
- 用途：配合治具零件的組成，作支持工件之用
- 特長：支持黑皮面之工件，使其不易滑動

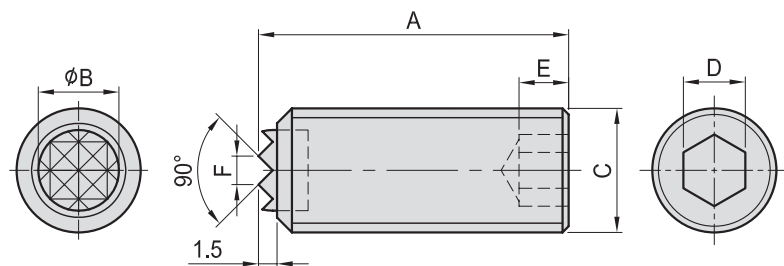

MODEL NO.	A	B	C	D	E	F	kg
PT18-1025	25	6.5	M10	5	4	2.3	0.015
PT18-1050	50						0.030
PT18-1225	25	8.0	M12	6	5	2.3	0.022
PT18-1250	50						0.045
PT18-1625	25	11.5	M16	8	6	3.0	0.038
PT18-1650	50						0.078
PT18-2025	25	13.0	M20	10	8	3.0	0.058
PT18-2050	50						0.120

- 齒盤
- 材質：SKH9
 - 熱處理：HRC60°
 - 表面：染黑處理

MODEL NO.	A	B	C	D	E	F	kg
PT18-1025-K	25	6.5	M10	5	4	2.3	0.015
PT18-1050-K	50						0.030
PT18-1225-K	25	8.0	M12	6	5	2.3	0.022
PT18-1250-K	50						0.045
PT18-1625-K	25	11.5	M16	8	6	3.0	0.038
PT18-1650-K	50						0.078
PT18-2025-K	25	13.0	M20	10	8	3.0	0.058
PT18-2050-K	50						0.120

- 齒盤
- 材質：鎢鋼
 - 表面：染黑處理

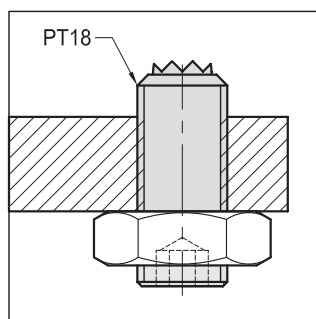

PT19

齒型螺桿 GRIPPER SCREW



- 材質：本體 SCM435
- 熱處理：本體 HRC 32°~38°
- 表面：染黑處理
- 用途：配合治具零件的組成，作支持工件之用
- 特長：支持黑皮面之工件，使其不易滑動

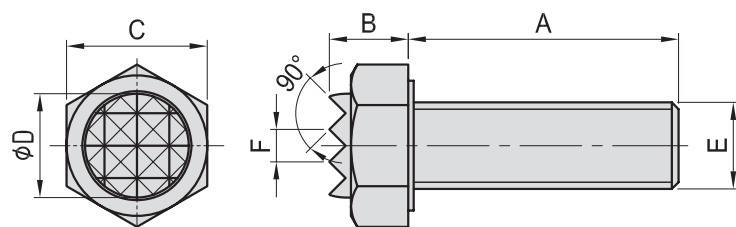

MODEL NO.	A	B	C	D	E	F	kg
PT19-061025	25	6.0	10	7.9	M6	2.3	0.008
PT19-081325		7.3	13	9.5	M8	3.0	0.015
PT19-101725	25	8.4	17	12.7	M10	3.0	0.030
PT19-101740	40						0.035
PT19-121925	25	9.5	19	15.9	M12	3.0	0.035
PT19-121940	40						0.050
PT19-162435	35	12.0	24	19.1	M16	3.0	0.085
PT19-162450	50						0.100
PT19-203040	40	14.5	30	25.4	M20	3.0	0.160
PT19-203060	60						0.205

- 齒盤
- 材質：SKH9
 - 熱處理：HRC 60°
 - 表面：染黑處理

MODEL NO.	A	B	C	D	E	F	kg
PT19-061025-K	25	6.0	10	7.9	M6	2.3	0.008
PT19-081325-K		7.3	13	9.5	M8	3.0	0.015
PT19-101725-K	25	8.4	17	12.7	M10	3.0	0.030
PT19-101740-K	40						0.035
PT19-121925-K	25	9.5	19	15.9	M12	3.0	0.035
PT19-121940-K	40						0.050
PT19-162435-K	35	12.0	24	19.1	M16	3.0	0.085
PT19-162450-K	50						0.100
PT19-203040-K	40	14.5	30	25.4	M20	3.0	0.160
PT19-203060-K	60						0.205

- 齒盤
- 材質：鎢鋼
 - 表面：染黑處理

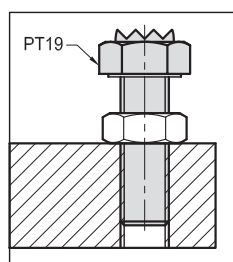

PT20

齒型支持件 GRIPPER PAD(SQUARE)



- 材質：SKH9
- 熱處理：HRC 60°
- 表面：染黑處理
- 用途：支持黑皮面工件用

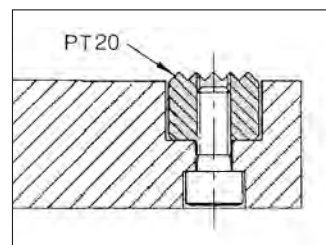
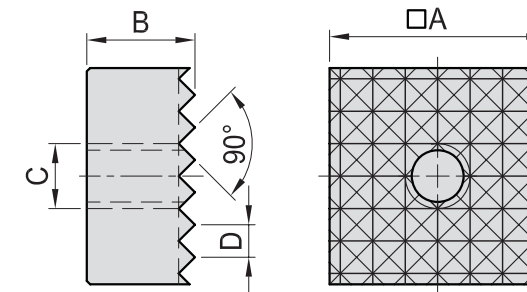

MODEL NO.	A	B	C	D	kg
PT20-1010	10	10	M5	2.3	0.008
PT20-1210	12				0.010
PT20-2010	20	10	M6	3.0	0.030
PT20-2510	25				0.043

PT21

齒型支持件 GRIPPER PAD(ROUND)



- 材質：本體 S45C
- 熱處理：本體 HRC 33°
- 表面：染黑處理
- 用途：支持黑皮面之工件

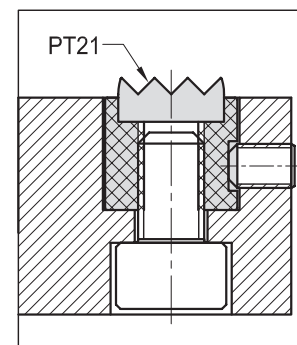
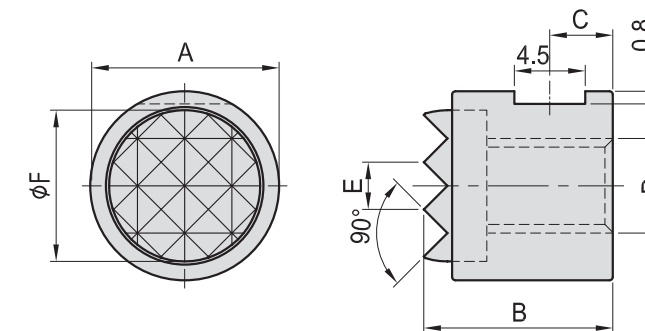

MODEL NO.	A	B	C	D	E	F	kg
PT21-1010	10	10.0	3.4	M5	2.3	8.1	0.005
PT21-1212	12	12.0	4.0	M6	3.0	9.6	0.008
PT21-1612	16					13.0	0.016
PT21-2012	20	12.0	4.0	M6	3.0	16.3	0.025
PT21-2512	25					19.5	0.040

- 齒盤
- 材質：SKH9
 - 熱處理：HRC 60°
 - 表面：染黑處理

MODEL NO.	A	B	C	D	E	F	kg
PT21-1010-K	10	10.0	3.4	M5	2.3	8.1	0.005
PT21-1212-K	12	12.0	4.0	M6	3.0	9.6	0.008
PT21-1612-K	16					13.0	0.016
PT21-2012-K	20	12.0	4.0	M6	3.0	16.3	0.025
PT21-2512-K	25					19.5	0.040

- 齒盤
- 材質：鎢鋼
 - 表面：染黑處理

PT22

墊圈 SPACER

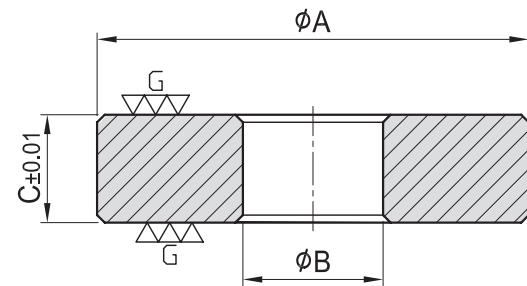

- 材質：S45C
- 熱處理：HRC 40°
- 用途：配合治具零件，作加高或延長之輔助

MODEL NO.	A	B	C	kg
PT22-1303	40	13	3	0.030
PT22-1305			5	0.045
PT22-1310			10	0.100
PT22-1330			30	0.300
PT22-1703	50	17	3	0.035
PT22-1705			5	0.070
PT22-1710			10	0.350
PT22-1730			30	0.950

PT23

開口墊圈 "C" WASHER

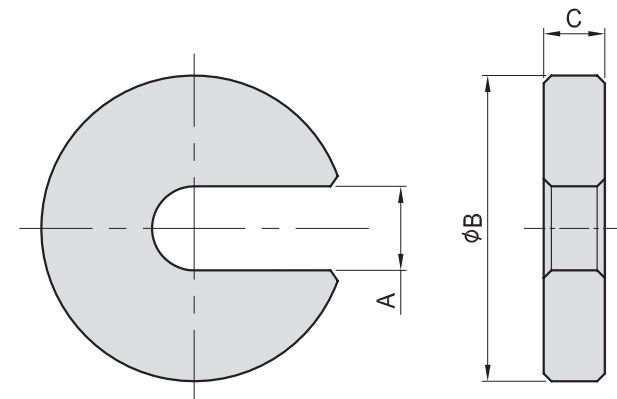

- 材質：S45C
- 熱處理：HRC 40°
- 用途：配合螺帽對工件作夾持之用
- 特長：拆裝工件，螺母不必全部脫離

MODEL NO.	A	B	C	kg
PT23-0835	9	35	8	0.065
PT23-1040	11	40		0.065
PT23-1255	13	55	10	0.150
PT23-1665	17	65		0.200
PT23-2080	21	80	10	0.300
PT23-2490	25	90	12	0.470



- 材質：4140
- 熱處理：HRC 40°
- 表面：染黑處理
- 用途：墊於工件之夾緊面
- 特長：拆裝方便

PT24

鉤型墊圈 SWING "C" WASHER

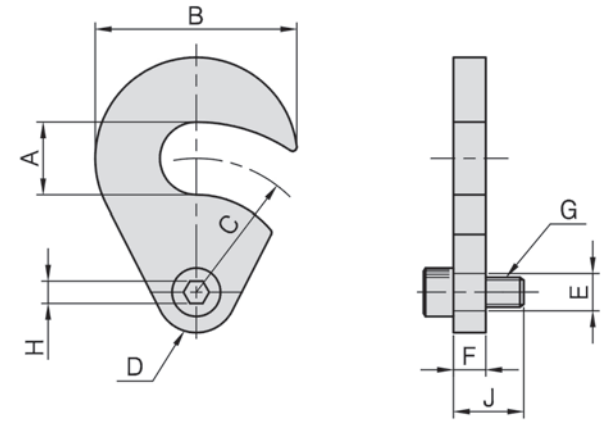

MODEL NO.	A	B	C	D	E	F	G	H	J	kg
PT24-0632	11.0	32	24	16	8	6	M6	8	15	0.050
PT24-0840	13.5	40	27	20	10	8	M8	10	20	0.090
PT24-0850	18.0	50	33	20	10	8	M8	10	20	0.130

PT25

球型墊圈 SPHERICAL WASHER

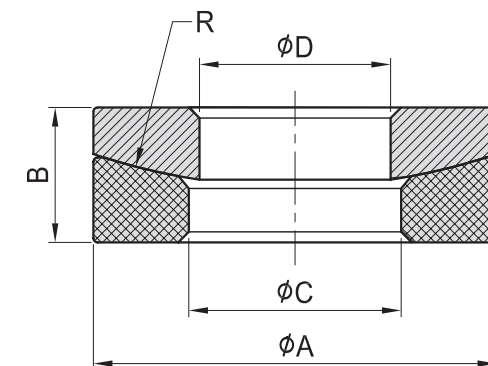

- 材質：S45C
- 熱處理：HRC 38°
- 表面：染黑處理
- 用途：墊於螺帽下方，隨壓板作適當的傾斜

MODEL NO.	A	B	C	D	R	kg
PT25-0819	19	6.2	10	9	30	0.013
PT25-1022	22	8.0	12	11		0.019
PT25-1226	26	7.5	15	13	40	0.024
PT25-1428	28	9.0	16	15		0.033
PT25-1632	32		19	17	0.058	
PT25-1835	35	10.0	20	19	48	0.050
PT25-2040	40	11.8	23	21		0.089
PT25-2245	45	12.5	26	24	70	0.110
PT25-2450	50	13.5	28	27		0.150

PT26

定位鍵 LOCATING KEY

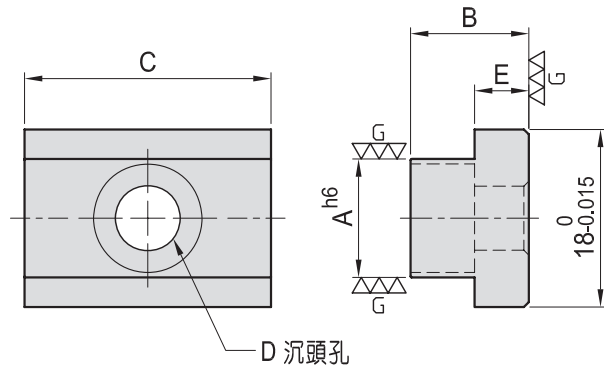

- 材質：S45C
- 熱處理：HRC 50°
- 用途：用於各治具零件與 T 形溝基板或基座組合之定位用

MODEL NO.	A	B	C	D	E	kg
PT26-1812	12	12	25	M6	5.5	0.035
PT26-1814	14					0.040
PT26-1816	16					0.040
PT26-1820	20					0.040
PT26-1822	22					0.040

PT27

定位鍵 LOCATING KEY

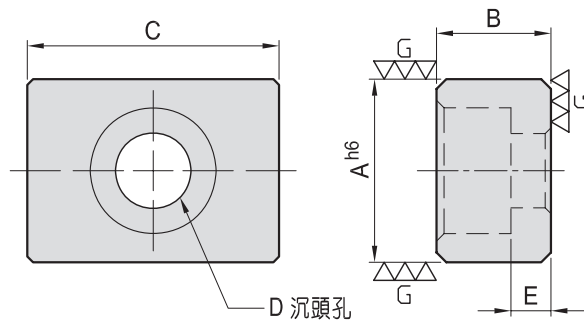

- 材質：S45C
- 熱處理：HRC 45°~50°
- 用途：用於各治具零件與 T 形溝基板或基座組合之定位用

MODEL NO.	A	B	C	D	E	kg
PT27-1008	10	8	20	M4	3.5	0.015
PT27-1208	12			M5	2.5	0.019
PT27-1410	14	10	22	M6	3.5	0.020
PT27-1610	16					0.025
PT27-1810	18					0.025
PT27-2010	20					0.025
PT27-2210	22					0.030

PT28

動向連結件 SWIVEL JOINT SUPPORT



- 材質：S45C
- 熱處理：HRC 32°~38°
- 表面：染黑處理
- 用途：與 PT09 配合組成可活動式之夾具

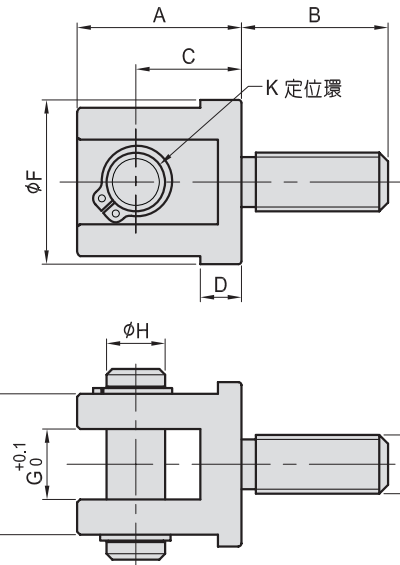
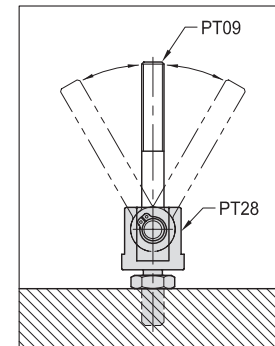

MODEL NO.	A	B	C	D	E	F	G	H	J	K	kg
PT28-1025	28	25	18	7.0	24	28	12	10	M10	10	0.055
PT28-1230	34	30	21	7.5	25	30	14	12	M12	12	0.105
PT28-1640	42	40	26	9.0	34	40	17	16	M16	16	0.210
PT28-2050	52	50	32	11.0	42	50	22	20	M20	20	0.300

PT29

動向支持座 SWIVEL PAD



- 材質：S45C
- 熱處理：HRC 32°~38°
- 表面：染黑處理
- 用途：與螺栓組合，可作為支持壓板之用
- 特長：隨壓板做適當的傾斜

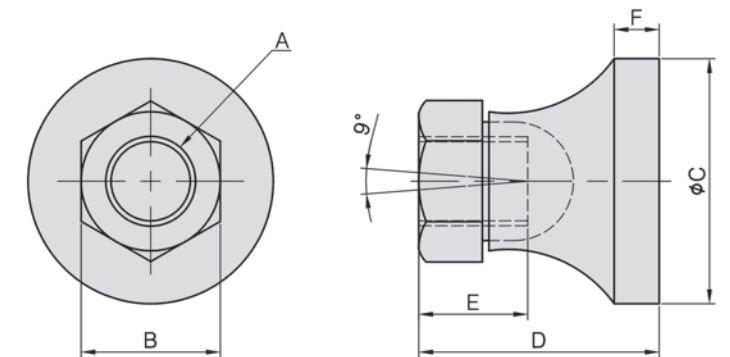
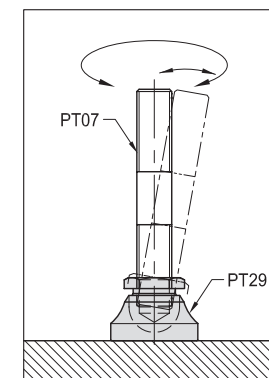

MODEL NO.	A	B	C	D	E	F	kg
PT29-1219	M12	19	35	24	11	7	0.080
PT29-1624	M16	24	40	29	13	8	0.150
PT29-2029	M20	29	50	40	18	10	0.300

PT30

吊環 LIFTING EYEBOLT

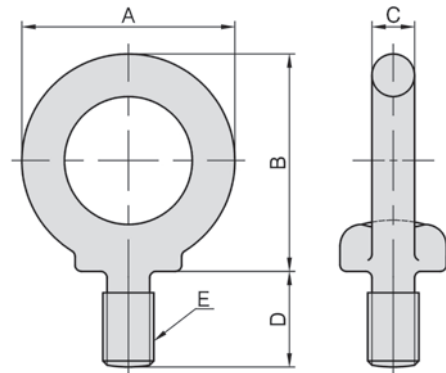

MODEL NO.	A	B	C	D	E	Load kg	kg
PT30-08	32.6	33.3	6.3	15	M 8	80	0.032
PT30-10	41.0	41.5	8.0	18	M10	150	0.063
PT30-12	50.0	51.0	10.0	22	M12	220	0.125
PT30-16	60.0	60.0	12.5	27	M16	450	0.216
PT30-20	72.0	71.0	16.0	30	M20	630	0.400
PT30-24	90.0	90.0	20.0	38	M24	950	0.830
PT30-30	110.0	110.0	25.0	45	M30	1500	1.500
PT30-36	133.0	131.5	31.5	55	M36	2300	2.900
PT30-42	151.0	150.5	35.5	65	M42	3400	4.400

PT31

定位螺栓 SHOULDER BOLT

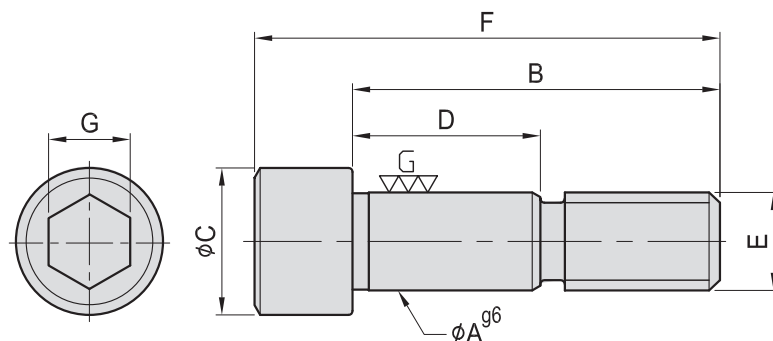

- 材質：SCM435
- 熱處理：HRC 32°~38°
- 表面：染黑處理
- 用途：可同時作固定治具與定位之用

MODEL NO.	A	B	C	D	E	F	G	kg
PT31-1245	12	45	18	23	M12	57	10	0.053
PT31-1255		55		33		67		0.060
PT31-1265		65		43		77		0.070
PT31-1275	16	75	24	53	M16	87	14	0.078
PT31-1655		55		28		72		0.120
PT31-1665		65		40		82		0.140
PT31-1675		75		50		92		0.150
PT31-1688	88	68	105	0.165				



- 材質：SCM435
- 熱處理：HRC 55°
- 用途：作各治具零件之定位用

PT32

異徑定位梢 SHOULDER DOWEL PIN

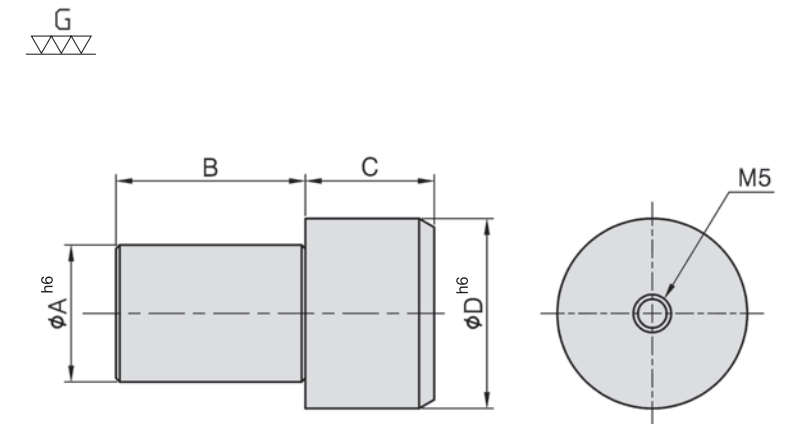

MODEL NO.	A	B	C	D	kg
PT32-081225	8	13	12	12	0.012
PT32-121632	12	18	14	16	0.032
PT32-142037	14	22	15	20	0.052
PT32-162239	16	22	17	22	0.072
PT32-182542	18	25	17	25	0.098

PT33

手輪螺帽 KNURLED NUT



- 材質：S45C
- 熱處理：HRC 32°~38°
- 表面：染黑處理
- 用途：與螺栓組成，可作微調之手輪

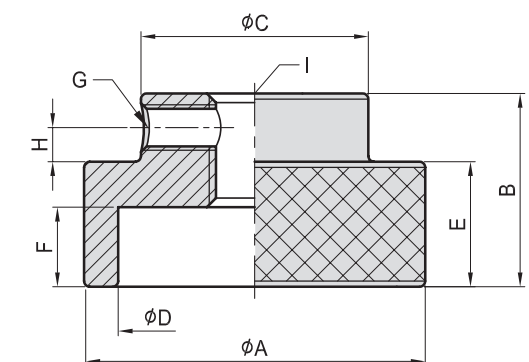

MODEL NO.	A	B	C	D	E	F	G	H	I	kg
PT33-0830	30	17	20	24	11	7	M4	3	M8	0.050
PT33-1035	35	20	28	30	13	8	M4	4	M10	0.090
PT33-1240	40	24	32	34	15	10	M5	4	M12	0.120
PT33-1645	45	30	35	38	18	12	M6	5	M16	0.180

PT34

護孔螺栓 PROTECTION PLUG

S45C(JIS) / CK45(DIN)
金屬

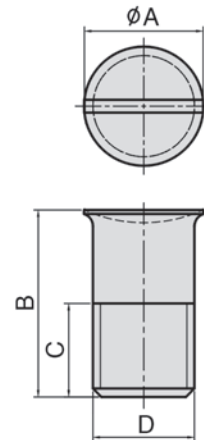

MODEL NO.	A	B	C	D	kg
PT34-10	11	19	10	M10	0.015
PT34-12	14	22	11	M12	0.018
PT34-16	18	25	13	M16	0.035

PBT 塑膠

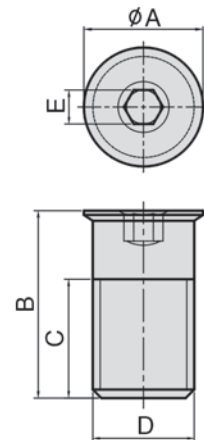

MODEL NO.	A	B	C	D	E	kg
PT34-12-PBT	14	22	14	M12	4	0.005
PT34-16-PBT	18	25	11	M16	5	0.010

AL 鋁合金

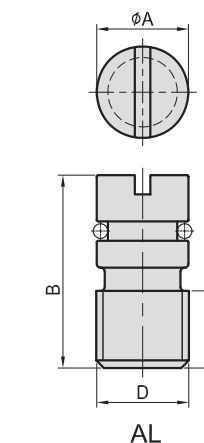

MODEL NO.	A	B	C	D	kg
PT34-12-AL	12	25	10	M12	0.007
PT34-16-AL	16	30	11	M16	0.015

- 材質：S45C
- 用途：保護定位孔用
- 特長：防止鐵屑滲入



- 材質：本體 S45C，鋼珠 SUJ2
- 硬度：本體 HRC 28°~32°
鋼珠 HRC 62°

PT35

齒面動向鋼珠螺桿支持件 SWIVELING JACK SCREW

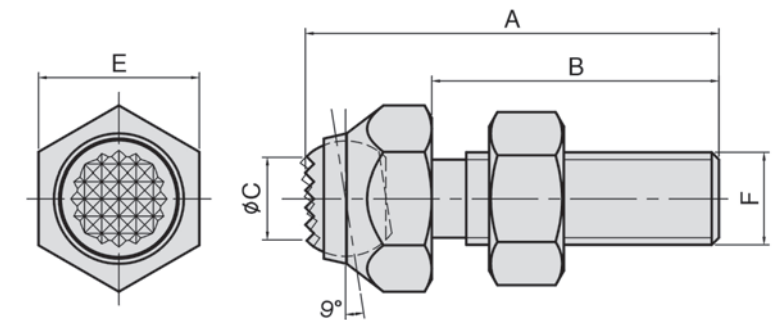

MODEL NO.	A	B	C	E	F	kg
PT35-0814	36	25	7	14	M8x1.25	0.025
PT35-1017	45	30	8	17	M10x1.50	0.055
PT35-1217	50	35	10	17	M12x1.75	0.055
PT35-1624	60	40	12	24	M16x2.00	0.140
PT35-2036	87	60	14	36	M20x2.50	0.330
PT35-2436	98	66	18	36	M24x2.00	0.660
PT35-3046	110	75	21	46	M30x2.00	1.100

PT36

平面動向鋼珠螺桿支持件 SWIVELING JACK SCREW

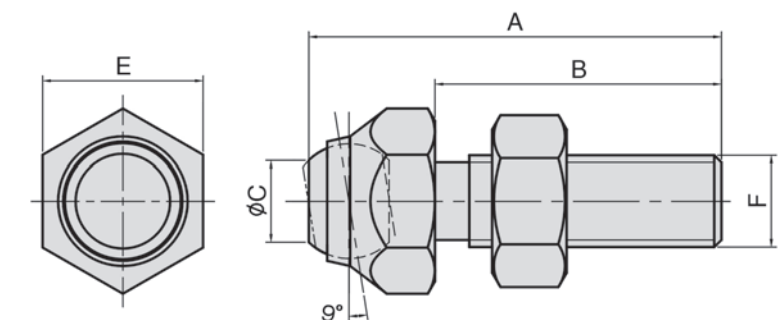

MODEL NO.	A	B	C	E	F	kg
PT36-0814	36	25	7	14	M8x1.25	0.025
PT36-1017	45	30	8	17	M10x1.50	0.055
PT36-1217	50	35	10	17	M12x1.75	0.055
PT36-1624	60	40	12	24	M16x2.00	0.140
PT36-2036	87	60	14	36	M20x2.50	0.330
PT36-2436	98	66	18	36	M24x2.00	0.660
PT36-3046	110	75	21	46	M30x2.00	1.100

- 材質：本體 S45C，鋼珠 SUJ2
- 硬度：本體 HRC 28°~32°
鋼珠 HRC 62°

BP

BPA

BC

CP

SU

PT

SVF

ALV

OK-
VISE

MITEE-
BITE

JER-
GENS

其他類

技術
資料

PT37

齒面動向鋼珠支持件 SWIVEL REST TIP

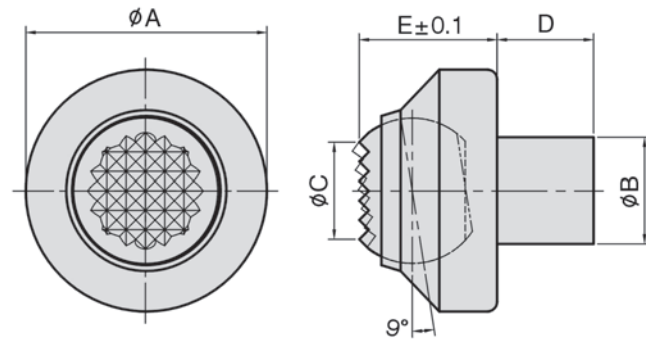

- 材質：本體 S45C，鋼珠 SUJ2
- 硬度：本體 HRC 28°~32°
鋼珠 HRC 62°

MODEL NO.	A	B	C	D	E	kg
PT37-1116	25	11	10	10	14.3	0.03
PT37-1118	30	11	12	10	18.0	0.04

PT39

螺桿支持件 CLAMP REST

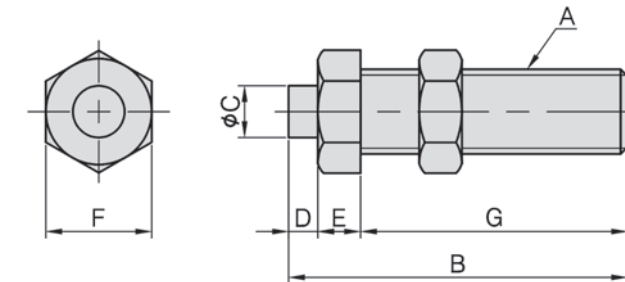

- 材質：S45C
- 硬度：HRC 35°

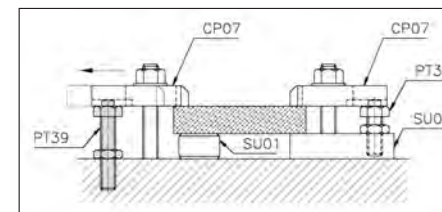

MODEL NO.	A	B	C	D	E	F	G	kg
PT39-1219	M12	75	9.5	6	9	19	60	0.09
PT39-1624	M16	80	11.0	7	10	24	63	0.17
PT39-2030	M20	100	12.0	8	12	30	80	0.35

PT38

迴轉式T型螺帽 ROTARY T-SLOT NUT

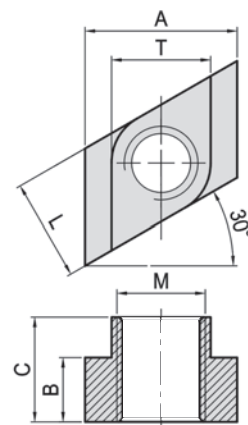

- 材質：SCM220
- 熱處理：HRC 30°~35°
- 表面：染黑處理

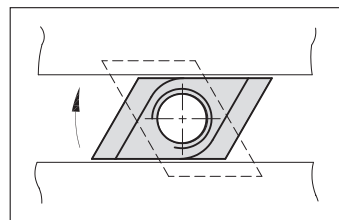

MODEL NO.	T	A	B	C	L	M	kg
PT38-1210	11.7	17.5	5.5	12.7	11.5	M10	0.010
PT38-1412	13.8	22.2	8.7	15.8	13.5	M12	0.023
PT38-1614	15.8	25.4	8.7	15.8	15.5	M14	0.030
PT38-1816	17.8	28.5	11.1	19.0	17.5	M16	0.030
PT38-2018	19.7	31.7	11.9	19.0	19.5	M18	0.044
PT38-2220	21.7	36.0	13.8	25.4	21.5	M20	0.062
PT38-2420	23.5	38.2	14.0	25.4	23.5	M20	0.092
PT38-2824	26.9	41.3	17.5	28.5	27.5	M24	0.162

BP

BPA

BC

CP

SU

PT

SVF

ALV

OK-
VISE

MITEE-
BITE

JER-
GENS

其他類

技術
資料

PT40

T型螺桿 T-SLOT BOLT

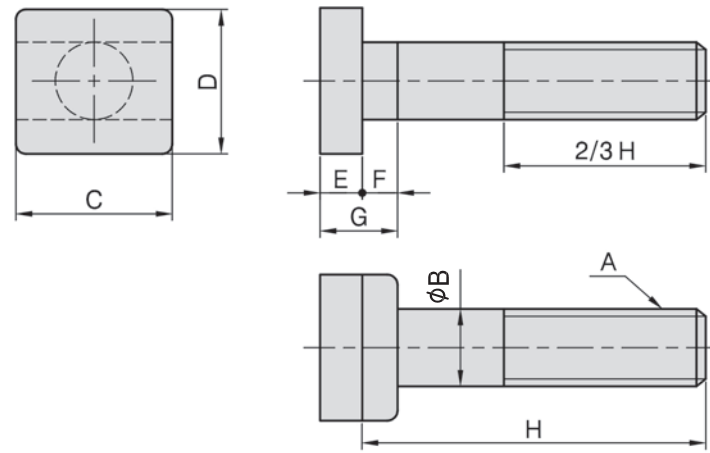

- 材質：S45C鍛造鋼
- 表面：染黑處理
- 硬度：HRC 32°~38°

MODEL NO.	A	B	C	D	E	F	G	H	kg
PT40-12050								50	0.054
PT40-12075								75	0.057
PT40-12100								100	0.110
PT40-12125	M12	12	26	22	7	6	13	125	0.125
PT40-12150								150	0.140
PT40-12175								175	0.170
PT40-12200								200	0.185
PT40-16050								50	0.130
PT40-16075								75	0.160
PT40-16100								100	0.200
PT40-16125	M16	16	32	27	8	8	16	125	0.230
PT40-16150								150	0.270
PT40-16175								175	0.305
PT40-16200								200	0.325
PT40-18075								75	0.270
PT40-18100								100	0.320
PT40-18125	M18	18	40	30	11	11	22	125	0.340
PT40-18150								150	0.385
PT40-18175								175	0.445
PT40-18200								200	0.490
PT40-20075								75	0.290
PT40-20100								100	0.350
PT40-20125								125	0.400
PT40-20150	M20	20	40	30	11	11	22	150	0.455
PT40-20175								175	0.505
PT40-20200								200	0.560
PT40-20250								250	0.660
PT40-20315								315	1.000
PT40-22100								100	0.450
PT40-22125								125	0.510
PT40-22150	M22	22	40	38	14	13	27	150	0.580
PT40-22175								175	0.635
PT40-22200								200	0.700
PT40-24100								100	0.650
PT40-24125								125	0.690
PT40-24150	M24	24	50	44	16	15	31	150	0.775
PT40-24175								175	0.855
PT40-24200								200	0.925



- 材質：S45C
- 硬度：HRC 32°~35°

PT41

球面螺帽 SWIVEL FLANGE NUTS

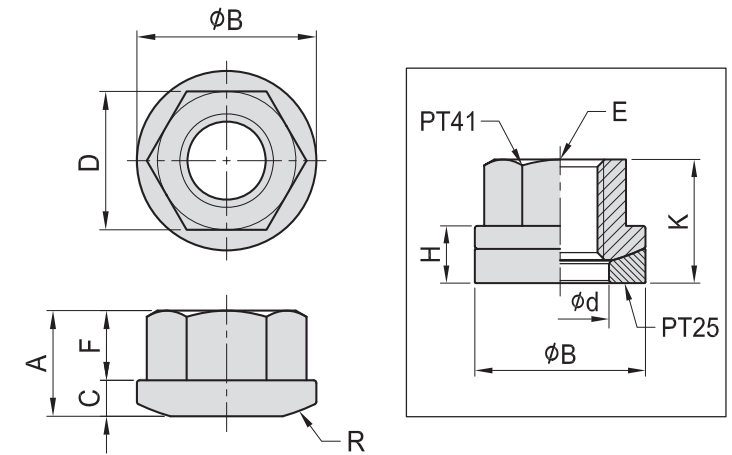

MODEL NO.	A	B	C	D	d	E	F	H	K	R	kg
PT41-0813	12.0	19	3.0	13	10	M8	7.8	7	15.0	30	0.021
PT41-1017	13.0	22		17	12	M10	8.4	8	16.5		0.032
PT41-1219	14.3	26	4.0	19	15	M12	9.0	10	19.0	32	0.046
PT41-1422	17.5	28	4.5	22	16	M14	11.4	11	22.0	40	0.066
PT41-1624	20.0	32		24	19	M16	12.8		23.8		0.103
PT41-1827	20.6	35		27	20	M18	13.6	12	25.5		0.106
PT41-2030	25.0	40	6.0	30	23	M20	16.6	14	31.0	48	0.183
PT41-2232	25.4	45		32	26	M22	16.9		31.5	70	0.210
PT41-2436	28.0	50		36	28	M24	18.7	15	33.5		0.270

PT42

T型螺帽素材 T-SLOT NUT-BLANK



- 材質：S45C

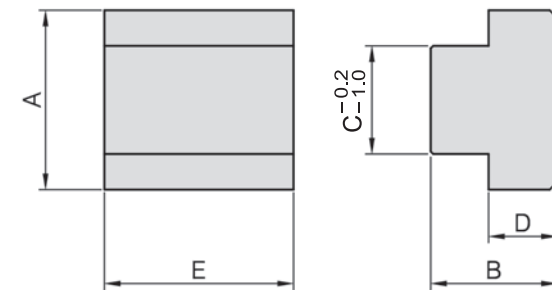

MODEL NO.	A	B	C	D	E	kg
PT42-1022	15.8	12.7	10	4.7	22	0.026
PT42-1222	17.5		12	5.5		0.032
PT42-1428	22.2	15.8	14	8.7	28	0.064
PT42-1628	25.4		16	8.7		0.073
PT42-1830	28.5	19.0	18	11.1	30	0.112
PT42-2030	31.7		20	11.9		0.128
PT42-2238	36.0	25.0	22	13.8	38	0.223
PT42-2438	38.2		24	14.0		0.239
PT42-2644	41.3	25.0	26	15.8	44	0.309
PT42-2850	44.0	28.5	28	17.5	50	0.403

BP

BPA

BC

CP

SU

PT

SVF

ALV

OK-
VISE

MITEE-
BITE

JER-
GENS

其他類

技術
資料

PT43

牙套 THREADED INSERT

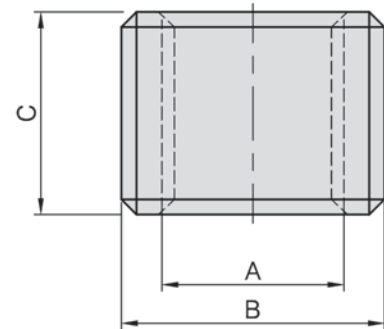

- 材質：S45C
- 硬度：HRC 32°~35°

MODEL NO.	A	B	C	kg
PT43-0612-10	M6x1.00	M12x1.5	10	0.005
PT43-0814-12	M8x1.25	M14x1.5	12	0.008
PT43-1016-15	M10x1.50	M16x1.5	15	0.010
PT43-1218-16	M12x1.75	M18x2.0	16	0.015
PT43-1420-18	M14x2.00	M20x2.0	18	0.300
PT43-1622-14	M16x2.00	M22x2.0	14	0.020
PT43-1622-20	M16x2.00	M22x2.0	20	0.025
PT43-2028-25	M20x2.50	M28x2.0	25	0.050

PT45

六角平面支持件 FEET(FLAT END)

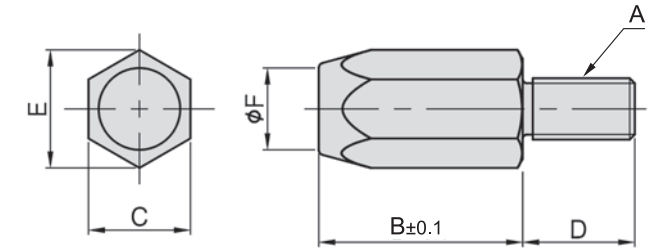

- 材質：S45C
- 熱處理：高週波
- 表面：染黑處理

MODEL NO.	A	B	C	D	E	F	kg
PT45-0610	M 6	10	10	11	11.5	8	0.008
PT45-0620		20					0.013
PT45-0815	M 8	15	14	13	16.1	10	0.018
PT45-0830		30					0.033
PT45-1020	M10	20	17	16	19.6	13	0.044
PT45-1040		40					0.080
PT45-1225	M12	25	19	20	21.9	15	0.070
PT45-1250		50					0.126
PT45-1630	M16	30	24	25	27.7	20	0.130
PT45-1660		60					0.230
PT45-2030	M20	30	30	25	34.6	28	0.200
PT45-2060		60					0.360

PT44

襯套 POSITIONING BUSHING



- 材質：SUJ2
- 硬度：HRC 60°

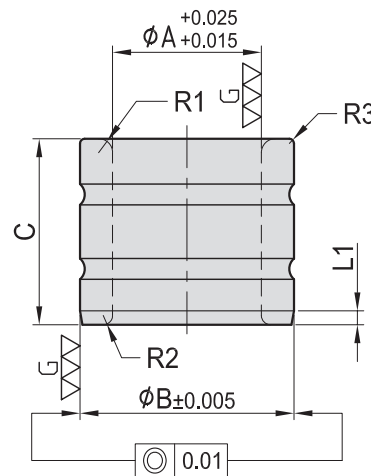

MODEL NO.	A	B	C	R1	R2	R3	L1	kg
PT44-0613-10	6	13	10	1.0	0.5	0.5	1.25	0.007
PT44-0815-10	8	15						0.009
PT44-1018-12	10	18	12	1.5	0.5	0.5	1.50	0.015
PT44-1220-12	12	20						0.017
PT44-1423-16	14	23	16	1.5	1.0	0.5	1.50	0.030
PT44-1523-16	15							0.028
PT44-1623-16	16	23	16	1.5	1.0	0.5	1.50	0.025
PT44-1623-20			20					0.030
PT44-1826-20	18	26	20	1.5	1.0	0.5	1.50	0.040
PT44-2030-20	20	30	20	2.0	1.5	0.5	2.50	0.060
PT44-2230-20	22	30						0.050
PT44-2535-20	25	35	25	2.0	1.5	0.5	2.50	0.070
PT44-3042-25	30	42						0.130
PT44-4055-30	40	55	30	3.0	2.0	1.0	3.00	0.255
PT44-5070-30	50	70						0.430

PT46

六角齒面支持件 FEET(SERRATED END)

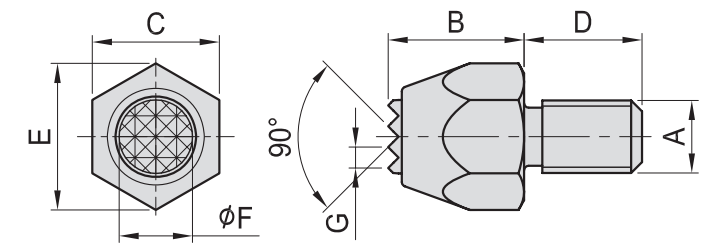

- 齒盤
- 材質：SKH9
 - 熱處理：HRC 60°

- 齒盤
- 材質：鎢鋼

- 材質：本體 S45C
- 熱處理：本體 HRC 28°~32°
- 表面：染黑處理
- 用途：配合治具零件的組成，作支持工件之用
- 特長：支持黑皮面之工件，不易滑動

MODEL NO.	A	B	C	D	E	F	G	kg
PT46-0610	M6	10	10	11	11.5	6.5	2.3	0.008
PT46-0620		20						0.013
PT46-0815	M8	15	14	13	16.1	8.1	2.3	0.018
PT46-0830		30						0.033
PT46-1020	M10	20	17	16	19.6	11.4	3.0	0.044
PT46-1040		40						0.080
PT46-1225	M12	25	19	20	21.9	13.0	3.0	0.070
PT46-1250		50						0.126
PT46-1630	M16	30	24	25	27.7	16.2	3.0	0.130
PT46-1660		60						0.230
PT46-2030	M20	30	30	25	34.6	25.2	3.0	0.200
PT46-2060		60						0.360

PT47-49

鋼珠滾輪 BALL ROLLERS

• 材質：SUS304

PT47

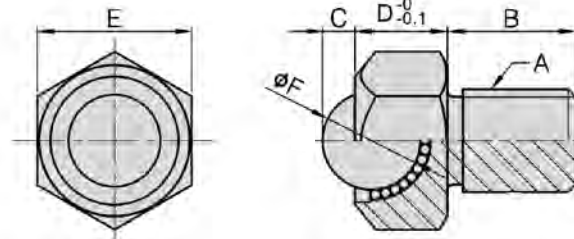

MODEL NO.	A	B	C	D	E	F	N(kgf)
PT47-1615	M16	20	3.3	16	24	15.87	343(35)
PT47-2018	M20	25	5.3	19	30	19.05	412(42)

PT48

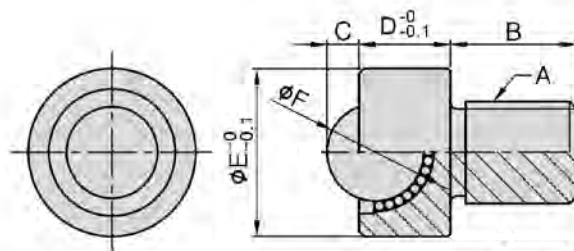

MODEL NO.	A	B	C	D	E	F	G	N(kgf)
PT48-1615	M16	20	3.3	16	27	15.87	23	343(35)
PT48-2018	M20	25	5.3	19	33	19.05	29	412(42)

PT49

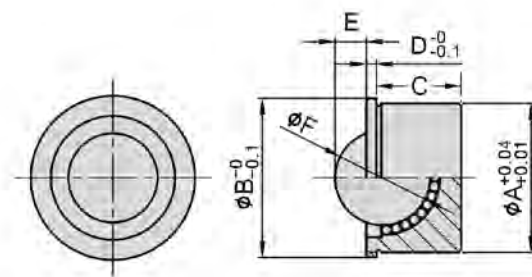

MODEL NO.	A	B	C	D	E	F	N(kgf)
PT49-2614	24	26	14	1.5	5.3	15.87	343(35)
PT49-3217	30	32	17	2.0	6.3	19.05	412(42)



PT50

平面動向鋼珠定位螺桿 SMOOTH BALL END BOLT

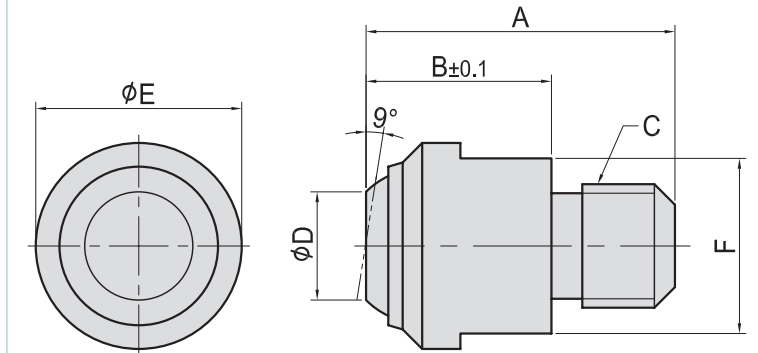

- 材質：本體 S45C
鋼珠 SUJ2
- 熱處理：本體 HRC 28°~32°
鋼珠 HRC 62°
- 表面：染黑處理
- 用途：適用於支持或挾持工件之斜面上使其不易變形

MODEL NO.	A	B	C	D	E	F	max (KN)	g
PT50-0613	21	13	M6x1.00	7.2	13	11	10	12
PT50-0813	21	13	M8x1.25	7.2	13	11	10	13
PT50-0818	28	18	M8x1.25	10.5	20	17	25	38
PT50-1018	28	18	M10x1.50	10.5	20	17	25	40
PT50-1218	30	18	M12x1.75	10.5	20	17	25	40
PT50-1627	43	27	M16x2.00	20.0	30	27	90	150
PT50-2035	55	35	M20x2.50	34.5	50	41	165	520

* 只適用於當需要最小孔深時

PT51

齒面動向鋼珠定位螺桿 SMOOTH BALL END BOLT

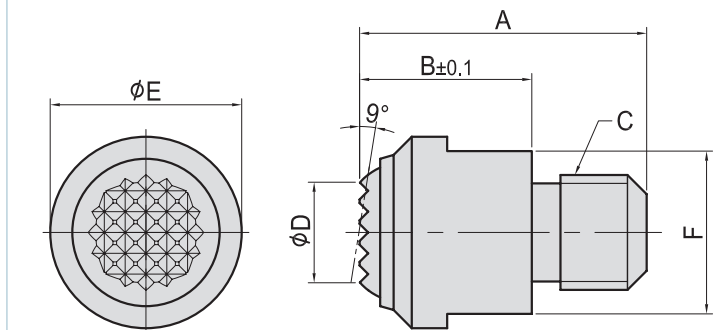

- 材質：本體 S45C
鋼珠 SUJ2
- 熱處理：本體 HRC 28°~32°
鋼珠 HRC 62°
- 表面：染黑處理
- 用途：適用於支持或挾持工件之斜面上使其不易變形

MODEL NO.	A	B	C	D	E	F	max (KN)	g
PT51-0613	21	13	M6x1.00	7.2	13	11	10	12
PT51-0813	21	13	M8x1.25	7.2	13	11	10	13
PT51-0818	28	18	M8x1.25	10.5	20	17	25	38
PT51-1018	28	18	M10x1.50	10.5	20	17	25	40
PT51-1218	30	18	M12x1.75	10.5	20	17	25	40
PT51-1627	43	27	M16x2.00	20.0	30	27	90	150
PT51-2035	55	35	M20x2.50	34.5	50	41	165	520

* 只適用於當需要最小孔深時

BP

BPA

BC

CP

SU

PT

SVF

ALV

OK-
VISE

MITEE-
BITE

JER-
GENS

其他類

技術
資料

PT52

平面動向鋼珠支持件 SMOOTH BALL END BOLT

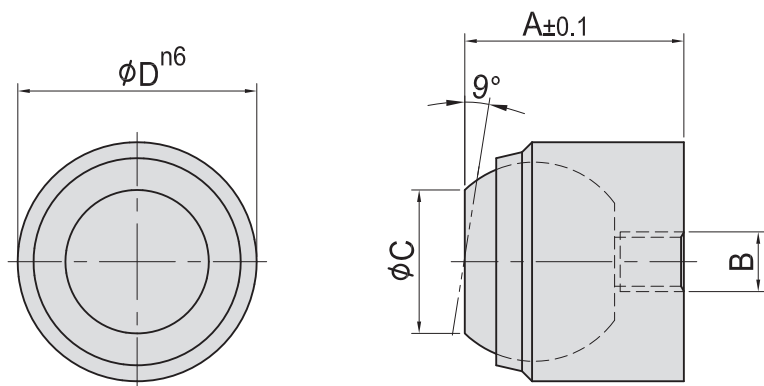

- 材質：本體 S45C
鋼珠 SUJ2
- 熱處理：本體 HRC 28°~32°
鋼珠 HRC 62°
- 表面：染黑處理
- 用途：適用於支持或挾持工件之斜面上使其不易變形

MODEL NO.	A	B	C	D	max (KN)	g
PT52-0311	11	M3x0.5	7.2	12	10	8
PT52-0417	17	M4x0.7	10.5	18	25	30
PT52-0525	25	M5x0.8	20.0	28	90	80

※只適用於當需要最小孔深時

PT53

齒面動向鋼珠支持件 SMOOTH BALL END BOLT

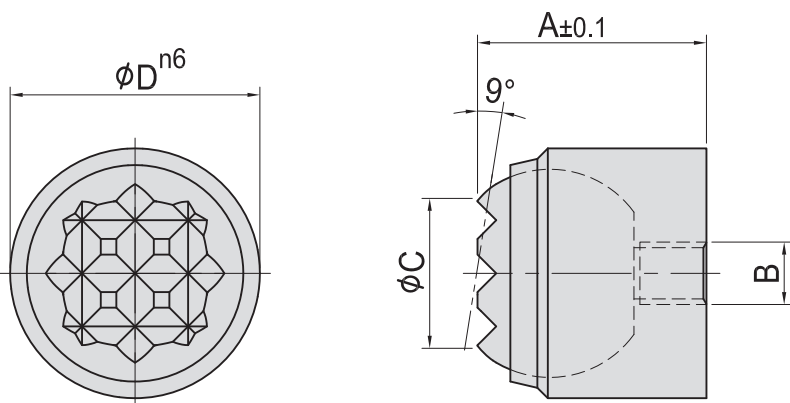

- 材質：本體 S45C
鋼珠 SUJ2
- 熱處理：本體 HRC 28°~32°
鋼珠 HRC 62°
- 表面：染黑處理
- 用途：適用於支持或挾持工件之斜面上使其不易變形

MODEL NO.	A	B	C	D	max (KN)	g
PT53-0311	11	M3x0.5	7.2	12	10	8
PT53-0417	17	M4x0.7	10.5	18	25	30
PT53-0525	25	M5x0.8	20.0	28	90	80

※只適用於當需要最小孔深時

PT55

側向式定位柱 (鋼材梢) SPRING LOCATING PINS



- | | |
|---------------------------|---------------------------|
| A型 | B型 |
| • 本體 材質：鋁
顏色：銀色 | • 本體 材質：鋁
顏色：銀色 |
| • 梢子 材質：鋼材
熱處理：HRC 35° | • 梢子 材質：鋼材
熱處理：HRC 35° |
| • 彈簧 材質：彈簧鋼 | • 彈簧 材質：彈簧鋼 |
| | • 膠封 材質：CR |

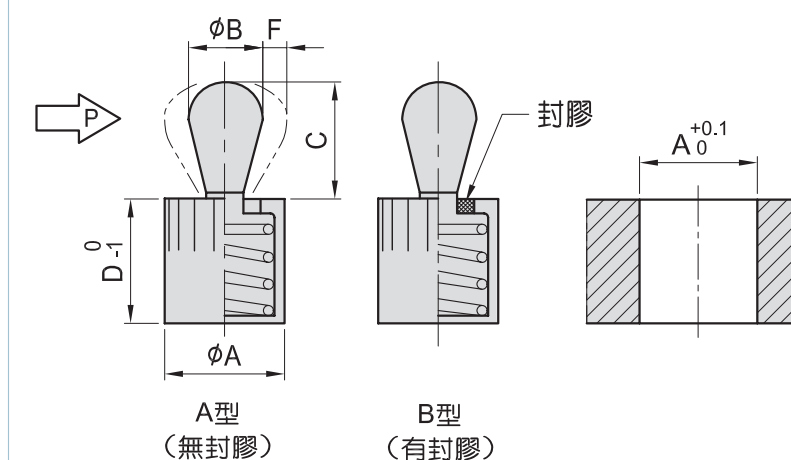

- 注意
- P(N)是梢子移動的最大力量
 - 耐溫範圍鋼材梢MAX250°C
 - 裝置方法請參考P.6-37
 - 組立棒請參考P.6-37

• 使用例：

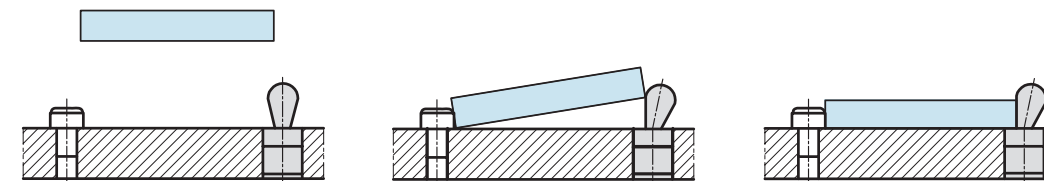

A型								B型									
MODEL NO.	A	B	C	D	F	P(N)	組立棒	g	MODEL NO.	A	B	C	D	F	P(N)	組立棒	g
PT55A-0603-010	6	3	4.0	7	0.5	10	PT57-0603	0.6	PT55B-0603-010	6	3	4	7	0.5	10	PT57-0603	0.6
PT55A-0603-020								20	PT55B-0603-020								20
PT55A-0603-040								40	PT55B-0603-040								40
PT55A-1005-020	10	5	6.7	11	0.8	20	PT57-1006	2.7	PT55B-1005-020	10	5	6	12	0.8	20	PT57-1006	2.7
PT55A-1005-050								50	PT55B-1005-050								50
PT55A-1005-100								100	PT55B-1005-100								100
PT55A-1006-040	10	6	10.7	11	1.0	40	PT57-1006	3.4	PT55B-1006-040	10	6	10	12	1.0	40	PT57-1006	3.4
PT55A-1006-075								75	PT55B-1006-075								75
PT55A-1006-150								150	PT55B-1006-150								150
PT55A-1208-050	12	8	13.9	13	1.3	50	PT57-1208	6.8	PT55B-1208-050	12	8	13	14	1.3	50	PT57-1208	7.0
PT55A-1208-100								100	PT55B-1208-100								100
PT55A-1208-200								200	PT55B-1208-200								200
PT55A-1610-100	16	10	16.7	17	1.6	100	PT57-1610	15.0	PT55B-1610-100	16	10	16	18	1.6	100	PT57-1610	15.0
PT55A-1610-200								200	PT55B-1610-200								200
PT55A-1610-300								300	PT55B-1610-300								300

PT56

側向式定位柱 (塑鋼梢) SPRING LOCATING PINS

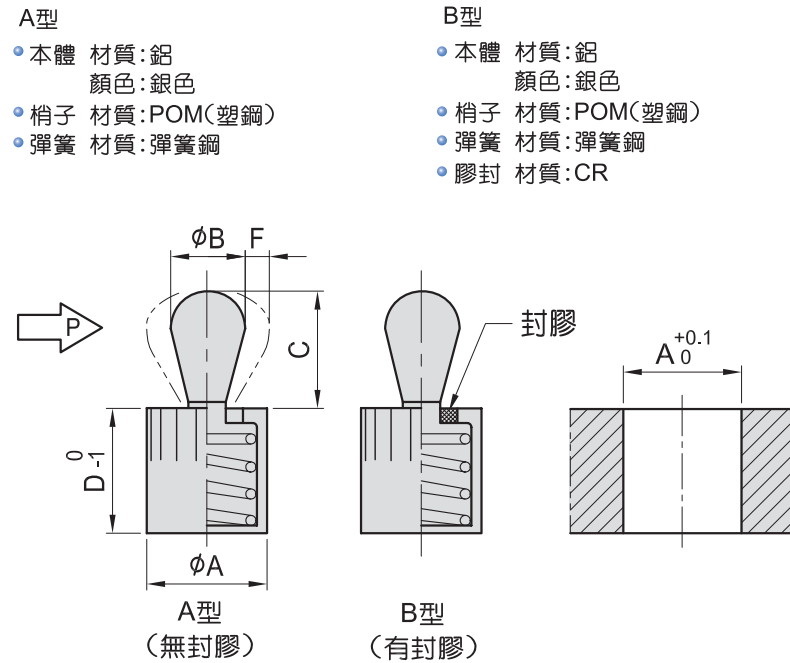

- A型**
- 本體 材質: 鋁 顏色: 銀色
 - 梢子 材質: POM(塑鋼)
 - 彈簧 材質: 彈簧鋼
- B型**
- 本體 材質: 鋁 顏色: 銀色
 - 梢子 材質: POM(塑鋼)
 - 彈簧 材質: 彈簧鋼
 - 膠封 材質: CR

- 注意
- P(N)是梢子移動的最大力量
 - 耐溫範圍塑鋼梢MAX80°C
 - 裝置方法請參考P.6-37
 - 組立棒請參考P.6-37

A型

MODEL NO.	A	B	C	D	F	P(N)	組立棒	g
PT56A-0603-010	6	3	4.0	7	0.5	10	PT57-0603	0.4
PT56A-1005-020	10	5	6.7	11	0.8	20	PT57-1006	1.3
PT56A-1006-040	10	6	10.7	11	1.0	40	PT57-1006	1.5
PT56A-1208-050	12	8	13.9	13	1.3	50	PT57-1208	2.9
PT56A-1610-100	16	10	16.7	17	1.6	100	PT57-1610	6.6

B型

MODEL NO.	A	B	C	D	F	P(N)	組立棒	g
PT56B-0603-010	6	3	4	7	0.5	10	PT57-0603	0.4
PT56B-1005-020	10	5	6	12	0.8	20	PT57-1006	1.3
PT56B-1006-040	10	6	10	12	1.0	40	PT57-1006	1.5
PT56B-1208-050	12	8	13	14	1.3	50	PT57-1208	3.0
PT56B-1610-100	16	10	16	18	1.6	100	PT57-1610	6.7

PT57

側向式定位柱組立棒 INSTALLATION TOOLS



- 材質: S45C
- 表面: 染黑處理

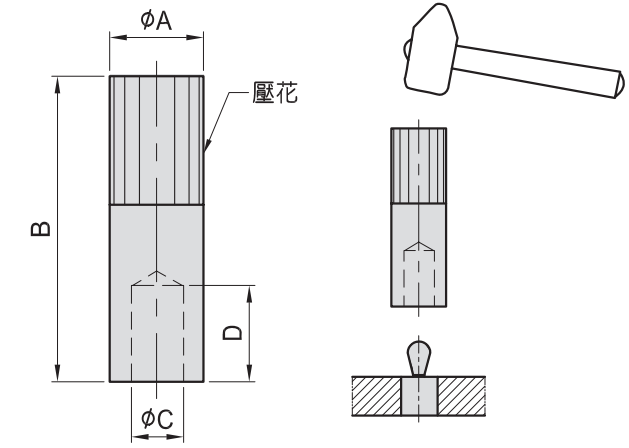

MODEL NO.	A	B	C	D	g
PT57-0603	8	50	3.2	6	19
PT57-1006	12	60	6.2	13	50
PT57-1208	14	60	8.1	16	65
PT57-1610	18	60	10.2	19	106

PT58

偏心塊 ECCENTRIC LINERS



- 材質: S45C
- 表面: 染黑處理

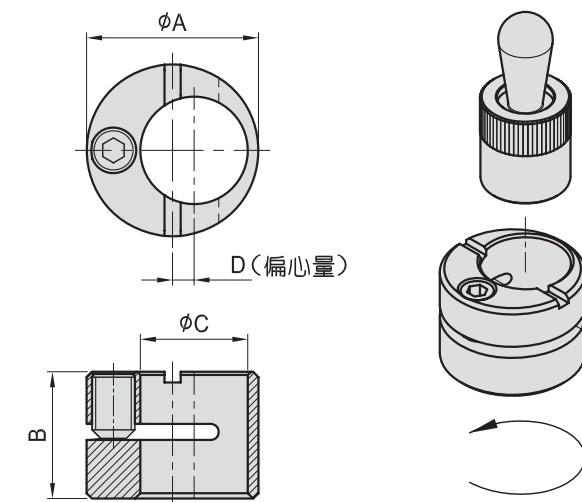

MODEL NO.	A	B	C	D	g
PT58-0612	12	9.9	6	2	5.5
PT58-1016	16	11.9	10	2	9.4
PT58-1218	18	13.9	12	2	12.8
PT58-1625	25	17.9	16	3	34.0

《裝置方式》

■ 裝置位置計算

依使用用途選擇適合的形式、規格，側向式定位柱的裝置位置，依下列計算求之：

裝置尺寸 = 工件寬 + X

X是從工作寬度邊緣到側向式定位柱裝置孔中心的距離。

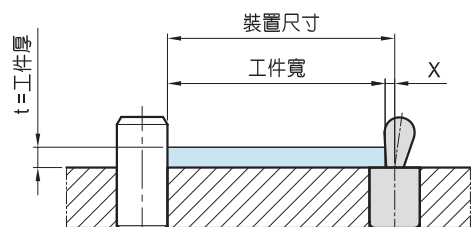

〈H的計算〉

H尺寸依下列計算式求之。

$$H=C-(B/2)$$

■ X計算

X尺寸必須考慮工件的厚度計算，有下列二種型式計算式。

(1) 工件厚度 < H時

$$X=B/2-F-[(C-B/2-t) \times 0.123]$$

(2) 工件厚度 > H時

$$X=B/2-F$$

工件較厚比H大時，和工件厚度無關，X值都一樣。

下表之X值是各種板厚與各型式規格組配計算而成，供設計參考使用。

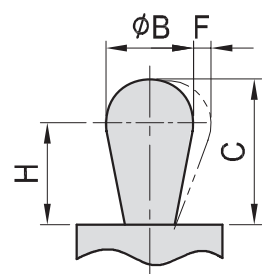

〈X尺寸一覽表〉

	梢子型式		H	工件厚度 (t)mm											
	鋼材製	塑膠製		1	2	3	4	5	6	8					
A型 無膠封	PT55A-0603-010	PT56A-0603-010	2.5	0.8	1.0	1.0	1.0	1.0	1.0	1.0	1.0				
	PT55A-0603-020														
	PT55A-0603-040														
	PT55A-1005-020	PT56A-1005-020	4.2	-	1.5	1.7	1.7	1.7	1.7	1.7	1.7				
	PT55A-1005-050														
	PT55A-1005-100														
	PT55A-1006-040	PT56A-1006-040	7.7	-	-	-	1.9	1.9	1.9	1.9	1.9				
	PT55A-1006-075														
	PT55A-1006-150														
	PT55A-1208-050	PT56A-1208-050	9.9	-	-	-	2.5	2.5	2.5	2.5	2.7				
	PT55A-1208-100														
	PT55A-1208-200														
PT55A-1610-100	PT56A-1610-100	11.7	-	-	-	3.1	3.1	3.1	3.1	3.1					
PT55A-1610-200															
PT55A-1610-300															
B型 有膠封	PT55B-0603-010	PT56B-0603-010	2.5	0.8	1.0	1.0	1.0	1.0	1.0	1.0					
	PT55B-0603-020														
	PT55B-0603-040														
	PT55B-1005-020	PT56B-1005-020	3.5	-	1.5	1.7	1.7	1.7	1.7	1.7	1.7				
	PT55B-1005-050														
	PT55B-1005-100														
	PT55B-1006-040	PT56B-1006-040	7.0	-	-	-	1.9	1.9	1.9	1.9	1.9				
	PT55B-1006-075														
	PT55B-1006-150														
	PT55B-1208-050	PT56B-1208-050	9.0	-	-	-	2.5	2.5	2.5	2.5	2.7				
	PT55B-1208-100														
	PT55B-1208-200														
PT55B-1610-100	PT56B-1610-100	11.0	-	-	-	3.1	3.1	3.1	3.1	3.1					
PT55B-1610-200															
PT55B-1610-300															

■ 裝置方法

側向式定位柱組立時，在本體外部塗上些許黃油再行壓入之。

《計算例1》

資料：側向式定位柱 PT55B-1006-075
鋼材梢(B型)

工件寬 100mm
工件厚 2.3mm

〈H的計算〉

工件厚和H尺寸的比較。

$$H=C-B/2=10-6/2=7(\text{mm})$$

因為工件厚度比H小，所以用(1)式求之。

〈X的計算〉

$$\begin{aligned} X &= B/2 - F - [(C - B/2 - t) \times 0.123] \\ &= 6/2 - 1 - [(10 - 6/2 - 2.3) \times 0.123] \\ &= 3 - 1 - [(4.7) \times 0.123] \\ &= 1.4(\text{mm}) \end{aligned}$$

〈裝置位置的計算〉

$$\begin{aligned} \text{裝置位置} &= \text{工件寬} + X \\ &= 100 + 1.4 \\ &= 101.4(\text{mm}) \end{aligned}$$

《計算例2》

資料：側向式定位柱 PT56A-1610-100
塑鋼梢(A型)

工件寬 300mm
工件厚 40mm

〈H的計算〉

工件厚度和H尺寸的比較。

$$H=C-B/2=16.7-10/2=11.7(\text{mm})$$

因為工件厚度比H大，所以用(2)式求之。

〈X的計算〉

$$\begin{aligned} X &= B/2 - F \\ &= 10/2 - 1.6 \\ &= 3.4(\text{mm}) \end{aligned}$$

〈裝置位置的計算〉

$$\begin{aligned} \text{裝置位置} &= \text{工件寬} + X \\ &= 300 + 3.4 \\ &= 303.4(\text{mm}) \end{aligned}$$

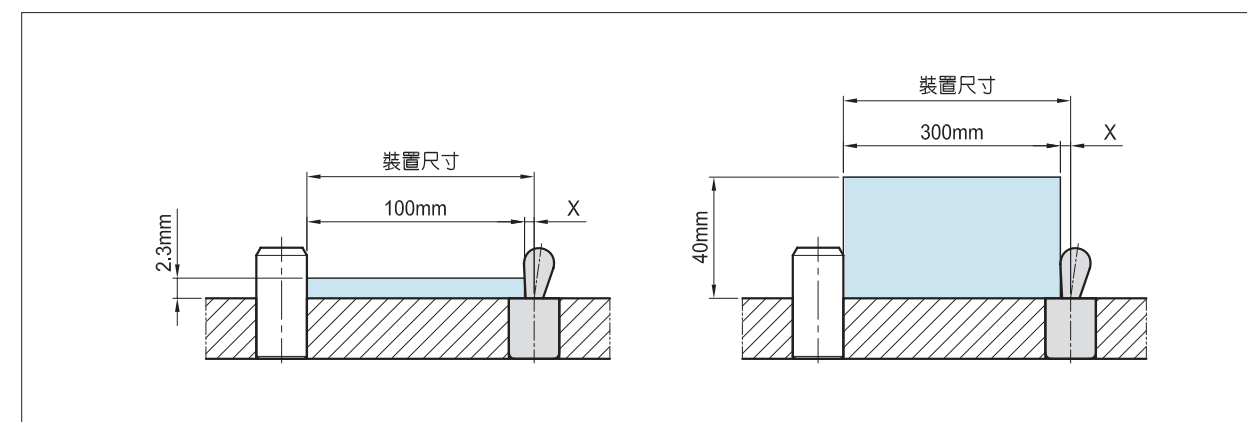
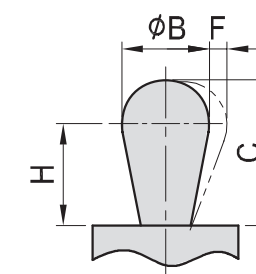

PT59

肩型襯套 POSITIONING BUSHING

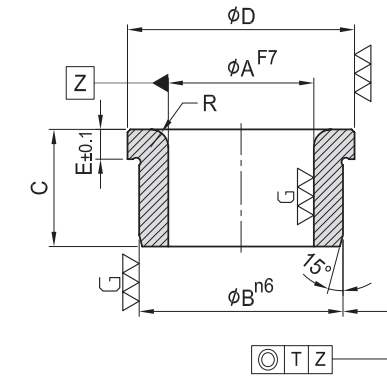

MODEL NO.	A	B	C	D	E	R	T
PT59-0615-10	6	12	10	15	3	1.5	0.01
PT59-0818-12	8	15	12	18	3	2.0	0.01
PT59-1022-12	10	18		22	4		
PT59-1266-16	12	22	16	26	4	2.0	0.01
PT59-1426-16	14						
PT59-1530-16	15	26	16	30	4	2.0	0.01
PT59-1630-16	16						
PT59-1834-20	18	30	20	34	5	3.0	0.01
PT59-2034-20	20						
PT59-2239-20	22	35	20	39	5	3.0	0.01
PT59-2539-20	25						
PT59-3052-25	30	48	25	52	5	3.0	0.01
PT59-4059-30	40						
PT59-5074-30	50	70	30	74	6	3.5	0.01



- 材質：SUJ2
- 熱處理：HRC 60°

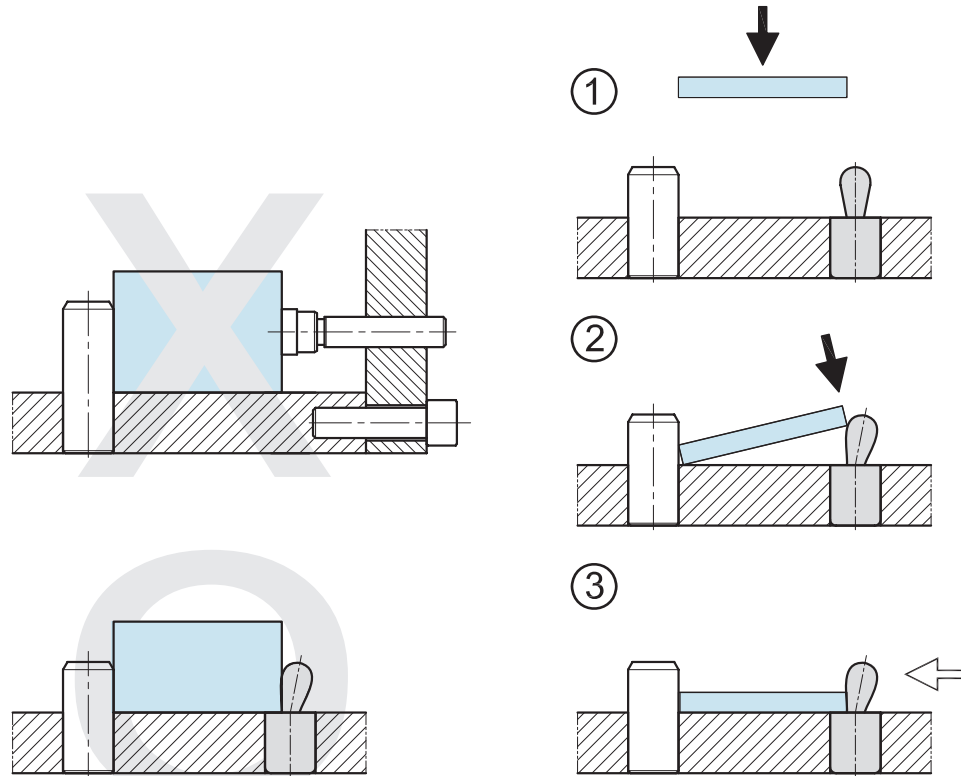

和傳統的固定方法比較，設計簡單可以大幅降低成本。

■ 側向式定位柱的使用例：

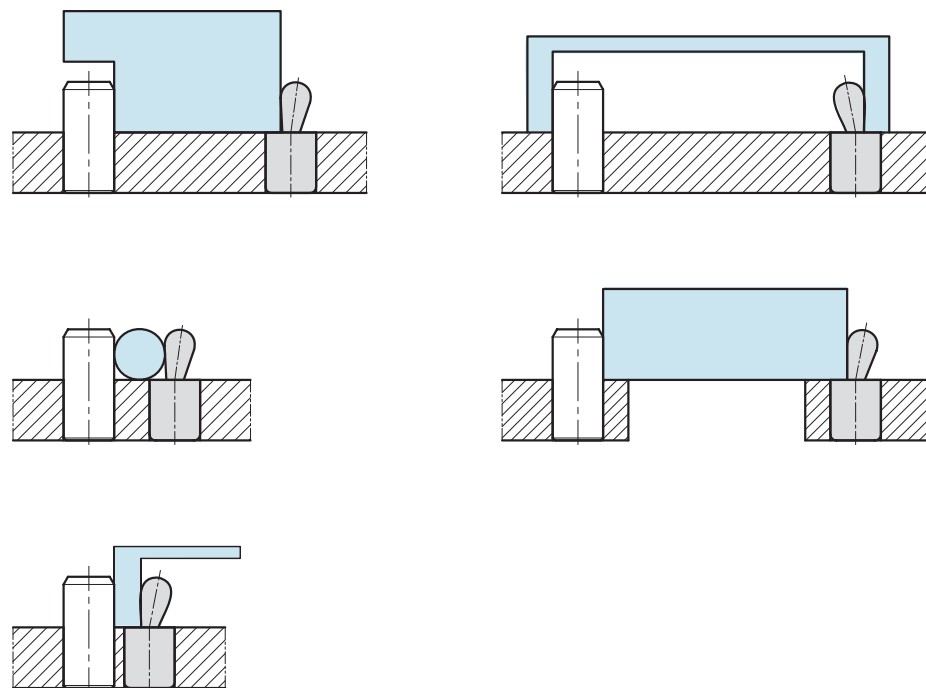

BP

BPA

BC

CP

SU

PT

SVF

ALV

OK-
VISE

MITEE-
BITE

JER-
GENS

其他類

技術
資料



A large area of the page is filled with horizontal blue lines, providing a space for handwritten notes or technical specifications.

BP

BPA

BC

CP

SU

PT

SVF

ALV

OK-
VISE

MITEE-
BITE

JER-
GENS

其他類

技術
資料